

## Operating Instructions



## Data Logger ALMEMO® 2690-8

V3.0  
15.10.2009

# 1. OPERATING CONTROLS



Back of unit:

**(8) Battery box**

3 Mignon Alkaline Batteries  
or 3 Mignon NiCd/NiMH Accumulators

**(9) Stand for stand and hang up**

(for opening out from 90° to 180°  
please press the stand together!)

**(1) Meas. inputs M0 to M4**

M0 ... M4 for all ALMEMO-Sensors  
M10...M34 15 additional channels

**(2) Output sockets A1, A2**

A1 Interfaces USB (ZA1919-DKU)  
Interface V24 (ZA 1909-DK5)  
Fiber optics V24 (ZA 1909-DKL)  
Ethernet (ZA 1945-DK)  
RS 422 (ZA 5099-NVL/NVB)  
Analog output 2 (ZA 1601-RK)  
A2 Network cable (ZA1999-NK5/NKL)  
SD card connector (ZA 1904-SD)  
Trigger input (ZA 1000-ET/EK)  
Relay outputs (ZA 1000-EGK)  
Analog output 1 (ZA 1601-RK)

**(3) Connector socket DC 12V**

Mains adapter (ZA1312-NA7, 12V, 1.0A)  
Charging adapter (ZA 2690-LA, 12V)  
DC-Cable isolat. (ZA 2690-UK, 10-30V)

**(4) Sleep-LED**

**(5) LCD display**

Status line:

- C** Cont. measuring point scan
- ▶, ||** Measurement Start, Stop
- REC** Memory record
- COM** Output of meas. values
- |▶, |▶** Meas. start, end programmed
- R01** Alarm relay status
- \***, **⊠** Light on, pause
- ▬** Battery operation/charge status

**13 lines for functions**

Function of keys F1, F2, F3, F4

**(6) Control keys**

- ON, <POFF>** Switch device on, off
- ▲, ▼, ▶** Function selection
- F1 ... F4** Function keys (soft keys)
- PROG** Programming
- ▲, ▼, ▶** Data input
- <ESC>** Function abort
- ◀** Last measuring menu

**(7) Rubber shock absorber**

## 2. TABLE OF CONTENTS

1. OPERATING CONTROLS.....	2
3. GENERAL.....	6
3.1 Guaranteed.....	6
3.2 Extent of the Delivery .....	7
3.3 Waste disposal.....	7
4. SAFETY INSTRUCTIONS.....	8
4.1 Special notes on use.....	9
4.2 Handling batteries / rechargeable batteries correctly.....	9
5. INTRODUCTION.....	9
5.1 Functions.....	10
5.1.1 Sensor Programming.....	10
5.1.2 Measurement.....	12
5.1.3 Process flow control.....	13
6. INITIAL OPERATION.....	15
7. POWER SUPPLY.....	16
7.1 Battery operation and Supply Voltage Control.....	16
7.2 Accumulator operation.....	16
7.3 Mains Operation.....	17
7.4 External DC Voltage Supply.....	17
7.5 Sensor Supply.....	17
7.6 Switch On/Off, Reinitialisation.....	17
7.7 Data buffering.....	17
8. CONNECTION OF THE TRANSDUCERS.....	18
8.1 Transducers.....	18
8.2 Measuring inputs and Additional Channels.....	18
8.3 Isolation.....	19
9. DISPLAY AND KEYPAD.....	20
9.1 Display and Menu Selection.....	20
9.2 Function Keys .....	21
9.3 Control Symbols.....	21
9.4 Function Selection.....	22
9.5 Data Entry.....	22
10. MEASURING USING MEASURING-MENUS.....	23
10.1 Measuring with one Measuring Point.....	24
10.1.1 Selecting the Measuring Point.....	24
10.1.2 Peak Value Memory with Time and Date.....	24
10.2 Correction of the Meas. Value and Compensation .....	25
10.2.1 Setting the Meas. Value to Zero.....	25
10.2.2 Zero Point Adjustment .....	26
10.2.3 Sensor Adjustment in the case of chemical sensors.....	26

10.2.4 Two-point Adjustment with Setpoint Entry.....	27
10.2.5 Temperature Compensation .....	28
10.2.6 Atmospheric Pressure Compensation.....	28
10.2.7 Cold Junction Compensation.....	29
<b>10.3 Measuring point scans and Output.....</b>	<b>30</b>
10.3.1 Single Output / Storage of all Measuring Points.....	30
10.3.2 Cyclic Output / Storage of all Measuring Points.....	30
10.3.3 Memory space, Memory Output, Clearing the Memory.....	31
10.3.4 Output of Menu Functions.....	31
10.3.5 Displaying Measured Values as a Line Diagram .....	32
<b>10.4 Averaging.....</b>	<b>33</b>
10.4.1 Damping of Meas. values by a Sliding averag. window.....	34
10.4.2 Averaging Mode.....	34
10.4.3 Averaging over Manual Single Measurements.....	34
10.4.4 Net Measurement.....	35
10.4.5 Averaging over the Measuring Time.....	36
10.4.6 Measurement Time, Measuring duration, Timer.....	36
10.4.7 Averaging over the Cycle.....	37
10.4.8 Averaging over several Measuring Points.....	38
10.4.9 Volume Flow Measurement.....	39
<b>10.5 Display of Several Measuring Points .....</b>	<b>40</b>
10.5.1 Menu Multi Channel Display and Bar chart.....	40
10.5.2 Differential Measurement.....	40
10.5.3 Menu List of Measuring Points.....	41
<b>10.6 Assistant-Menus for Special Meas. Operations.....</b>	<b>42</b>
10.6.1 Thermal Coefficient.....	42
10.6.2 Wet Bulb Globe Temperature.....	42
<b>10.7 User Menus.....</b>	<b>43</b>
10.7.1 Functions.....	43
10.7.2 Configuration of the menus .....	44
10.7.3 Function Printouts.....	45
<b>11. PROGRAMMING WITH PROGRAMMING-MENUS.....</b>	<b>46</b>
<b>11.1 Times and Cycles.....</b>	<b>46</b>
11.1.1 Time and Date .....	46
11.1.2 Cycle with Storage Activation and Output Format.....	46
11.1.3 Conversion Rate, Continuous Measuring Point Scan.....	47
11.1.4 Time and Date of Start, Time and Date of End .....	48
<b>11.2 Data Memory.....</b>	<b>49</b>
11.2.1 Memory connector with SD card.....	49
11.2.2 Data Acquisition.....	50
11.2.3 Numbering of measurements.....	51
11.2.4 Starting and Stopping of measurements.....	51
11.2.5 Scanning mode.....	51
11.2.6 Memory Output.....	53

<b>11.3 Sensor Programming</b> .....	<b>54</b>
11.3.1 Selecting the Input Channel.....	54
11.3.2 Measuring Point Designation.....	55
11.3.3 Averaging Mode.....	55
11.3.4 Locking the Programming of the Sensor.....	55
11.3.5 Limit Values.....	56
11.3.6 Scaling, Decimal Point Setting.....	56
11.3.7 Correction Values.....	57
11.3.8 Changing the Dimension.....	57
11.3.9 Selecting the Measuring Range.....	57
11.3.10 Function Channels.....	60
11.3.11 Special meas. ranges, linearization, multi-point calibration....	61
<b>11.4 Special Functions</b> .....	<b>62</b>
11.4.1 Print Cycle Factor.....	62
11.4.2 Minimum Sensor Supply Voltage.....	62
11.4.3 Limit Value Responses.....	63
11.4.4 Analog Output Start and End.....	64
11.4.5 Output Function.....	64
11.4.6 Reference Channel 1.....	65
11.4.7 Reference Channel 2 or Multiplexer.....	65
11.4.8 Element Flags.....	65
<b>11.5 Device Configuration</b> .....	<b>66</b>
11.5.1 Device Designation.....	66
11.5.2 Device Address and Networking.....	66
11.5.3 Baud Rate, Data Format.....	67
11.5.4 Language.....	67
11.5.5 Lighting and Contrast.....	67
11.5.6 Atmospheric Pressure.....	67
11.5.7 Hysteresis.....	68
11.5.8 Operating Parameters.....	68
<b>11.6 Output Modules</b> .....	<b>68</b>
11.6.1 Data cable.....	69
11.6.2 Relais Trigger modules.....	69
11.6.3 Analog Output.....	71
<b>11.7 Menu Power Supply</b> .....	<b>72</b>
<b>11.8 The locking and calibration menu (option KL)</b> .....	<b>73</b>
<b>12. TROUBLESHOOTING</b> .....	<b>74</b>
<b>13. DECLARATION OF CONFORMITY</b> .....	<b>75</b>
<b>14. APPENDIX</b> .....	<b>76</b>
<b>14.1 Technical Data</b> .....	<b>76</b>
<b>14.2 Product overview</b> .....	<b>77</b>
<b>15. Keyword index</b> .....	<b>78</b>
<b>15.1 Your contact</b> .....	<b>82</b>

## 3. GENERAL

Congratulations for buying this innovative ALMEMO® data logger. By means of the patented ALMEMO® connectors the device configures itself and with the help of menus and help windows the operation should not be too difficult. However, the device allows the connection of a great variety of sensors and peripherals with many special functions. For getting to know the function range of the sensors and the diverse possibilities of the device, you really should read these operating instructions and the corresponding chapters of the ALMEMO® manual. This is the only way to avoid operating and measuring errors as well as damages of the device. For a quick answer to all questions, a detailed keyword index is provided at the end of the instructions and of the manual.

### 3.1 Guaranteed

Every device has to pass through several quality tests before leaving the works. For a perfect function, a guarantee of two years from the delivery date is granted. Before sending back the device, please pay attention to the indications in chapter 12. Troubleshooting. Should there actually be a defect, please use the original packing material for depatch if possible and enclose an expressive description of the trouble in connection with the corresponding circumstances.

In the following cases a guarantee benefit is excluded:

- After forbidden operations and changes in the device by the client
- Operating in surrounding conditions that are not valid for this product
- Using unsuitable power supply and peripherals
- Using the device in a way it is not determined for
- Damages through electrostatic discharge or flash of lightning
- Not paying attention to the operating instructions

Changes in the product features in favour of technical progress or due to new components are reserved to the producer.

### 3.2 Extent of the Delivery

While unwrapping the delivery, pay attention to damages of the device and to its completeness:

Measuring device ALMEMO® 2690-8 with 3 alkaline-mignon-batteries,  
 Rubber shock absorber with a stand,  
 these operating instructions,  
 ALMEMO® Manual,  
 CD with Software AMR-Control and useful accessories

In case of a transportation damage, the packing material is to be kept and the supplier is to be informed immediately.

### 3.3 Waste disposal

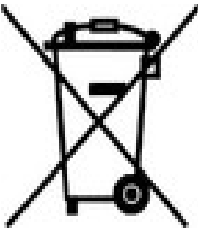

The pictogram showing a waste bin crossed through means that the product is subject to European Union regulations on segregated waste disposal. This applies both to the product itself and to any accessories marked with the same symbol. Disposal of any such item as unsorted domestic waste is strictly forbidden

- Please dispose of all packaging materials according to the applicable national waste management regulations.
- Please dispose of cardboard boxes, protective plastic packaging materials, and all preservative substances separately and in the proper manner.
- The disposal of the device itself (also of device parts, accessories, and consumables) is subject to the applicable national and local waste management regulations and to the environmental protection legislation in force in the country of use.
- Please dispose of all waste in the proper manner; this applies in particular to all parts and substances that constitute a hazard for the environment. This includes inter alia plastics, batteries, and rechargeable battery packs .
- When disposing of goods, please wherever possible use the original packaging materials.

## 4. SAFETY INSTRUCTIONS

**DANGER** Danger to life and limb, risk of damage to equipment



Read the instructions carefully before starting to operate the device.

Please ensure that you comply with all general safety advice and the special safety instructions included in other chapters.

Such risks may occur in the following circumstances :

- Failure to heed the operating instructions and all the safety notes these contain
- Any form of unauthorized tampering or alteration inside the device
- Use of the device in environments or conditions for which it is not suited
- Use of the device with an unsuitable power supply and / or in conjunction with unsuitable peripheral equipment
- Use of the device for any purpose other than that for which it is intended
- Damage caused by electrostatic discharge or lightning.

**DANGER** Risk of fatal injury caused by dangerously high voltage



Such risks may occur in the following circumstances :

- Use of the device with an unsuitable power supply and / or in conjunction with unsuitable peripheral equipment
- Damage caused by electrostatic discharge or lightning
- Do not run sensor lines in the vicinity of high-voltage power cables.
- Before you touch any sensor lines, ensure that all static electricity has been discharged.

**DANGER** Warning - explosive atmospheres or substances



In the vicinity of various fuels or chemicals there is a risk of explosion.

Do not use the device in the close vicinity of blasting work or filling stations!





## 4.1 Special notes on use

- If the device is brought into the work-room from a cold environment there is a risk that condensation might form on the electronics. In measuring operations involving thermocouples pronounced changes in temperature may cause substantial measuring errors. You are advised therefore to wait until the device has adjusted to the ambient temperature before starting to use it.
- Before using the mains adapter make sure that the mains voltage is suitable.
- Be sure to observe the maximum load capacity of the sensor power supply.
- Sensors with their own integrated power supply are not electrically isolated from one another

## 4.2 Handling batteries / rechargeable batteries correctly



When inserting batteries / rechargeable batteries ensure that these are correctly polarized.

If the device will probably not be needed for a relatively long period of time or if the batteries are empty, remove the batteries; this will prevent battery acid leaking onto the device and damaging it.

Rechargeable batteries should be recharged as and when necessary.

You should never attempt to recharge an ordinary (non-rechargeable) battery; it may explode !

Batteries / rechargeable batteries must never be short-circuited or thrown onto the fire.

Batteries / rechargeable batteries are special waste and must not be discarded together with normal domestic waste.

## 5. INTRODUCTION

The data logger **ALMEMO®** 2690-8 is a new instrument from the unique product range of measuring devices that are all equipped with the **ALMEMO®** connector system, which has been patented by Ahlborn GmbH. The intelligent **ALMEMO®** connector provides important advantages with regard to the connection of sensors and peripherals as all parameters are stored in an EEPROM within the connector. As a result, the programming that usually has to be performed for the connection is not required. All sensors and output modu-

les can be connected to all ALMEMO® measuring devices in the same way. The operation and programming is identical with all units. Therefore, all of the ALMEMO® measuring system items listed below are described, in detail, in a separate ALMEMO® manual that is supplied with every device:

- Detailed description of the ALMEMO® system (manual section 1)
- Overview of the device functions and measuring ranges (manual section 2)
- All sensors with basic principles, operation, technical data (man. section 3)
- The options for connecting existing sensors (manual section 4)
- All analog and digital output modules (manual section 5.1)
- The interface module RS232, fiber optics, Centronics (manual section 5.2)
- The entire ALMEMO® networking system (manual section 5.3)
- All functions and their control via the interface (manual section 6)
- A complete interface command list with all print outputs (manual section 7)

These operating instructions only cover features and controls that are specific for a certain device. As a result, many sections will often provide a note referring to the more detailed description within the manual (man. sect. x.x.x).

## 5.1 Functions

The ALMEMO® 2690-8 data logger has 5 electrically isolated measuring inputs for all ALMEMO® sensors. Over 20 channels in the sensor connectors and 4 device internal function channels with more than 70 measuring ranges are provided with unlimited measuring possibilities. The device can be operated by means of the LCD graphic display and a softkey keypad with cursor block. User menus can be configured to adapt the display for any application. The data logger function is carried out by a real time clock and a 512kB EEPROM memory for approximately 100000 measured values. Two output sockets allow for connecting any ALMEMO® output modules, for example, the digital interface, memory card, analogue output, trigger input or alarm contacts. Several devices can be networked by simply connecting them with network cables.

### 5.1.1 Sensor Programming

The measuring channels are automatically programmed by the ALMEMO® connectors. However, the user can easily complete or modify the programming via keyboard or via interface.

#### Measuring Ranges

There are corresponding measuring ranges for sensors with a non-linear characteristic such as 10 thermocouple types, Ntc and Pt100 sensors, infrared sensors, and flow sensors (rotating vanes, thermoanemometers, pitot tubes). Humidity sensors are available with function channels that also calculate humidity data such as dew point, mixture ratio, vapour pressure and enthalpy. Even complex chemical sensors can be used. The acquisition of measured data from other sensors is easily possible by using the voltage, current and resistan-

ce ranges with individual scaling in the connector. Existing sensors can be used without problems. Only the corresponding ALMEMO® connector has to be connected using its terminals. Furthermore, there are adapter connectors with an own microcontroller for digital signals and for measuring frequencies and pulses. This way, nearly all sensors can be connected to any ALMEMO® measuring instrument and are interchangeable without requiring any settings.

### **Function Channels**

Maximum, minimum, average values and differences of certain measuring junctions can be programmed as function channels, also in device internal channels, and can be processed and printed like normal measuring junctions. Furthermore, function channels for special measuring tasks are provided to determine the temperature coefficient  $Q/\Delta T$  and wet bulb globe temperature.

### **Dimension**

The 2 digit dimension can be altered for each measuring channel so that the display and the printout will always indicate the correct dimension, for example when a transmitter is connected. The conversion from °C to °F is automatically performed according to the dimension.

### **Name of Measured Values**

For identification of the sensors a 10-digit alphanumeric name is provided. It is entered via the keypad or the interface and appears on the display, the printout or the computer display.

### **Correction of Measured Values**

For correcting measured values a zero point and slope correction can be applied to the measured value of each measuring channel. This also allows for sensors to be interchanged that usually, at first, require an adjustment (expansion, force, pH). The zero point and the slope correction are virtually performed by the push of a button.

### **Scaling**

The base value and the factor allow for a further scaling of the corrected measured value of each measuring channel for zero point and slope. The decimal point position can be set by the exponent. By setting to zero and entering the nominal value the scaling values can be automatically calculated.

### **Limit Values and Alarm**

Two limit values (1 max and 1 min) can be set for each meas. channel. If a limit value is exceeded alarm contacts, that can be individually allocated to limit values, are provided by means of relay output modules. As a standard, the hysteresis is set to 10 digits; however, it can also be adjusted between 0 and 99 digits. Furthermore, limit value exceeding can also be used to start or stop a data logging.

### **Sensor Locking**

All sensor data stored in the EEPROM of the connector can be protected against undesired access by means of a graded locking function.

### 5.1.2 Measurement

A total of up to 20 meas. channels are available for 5 transducers, i.e. it is also possible to evaluate double sensors, individually scaled sensors, or sensors with function channels. The meas. channels can be successively selected forwards or backwards via keypad. By default all measuring points are scanned continuously at a measuring rate of 10 mops and the data thus obtained is listed on the display. However, if you want to have the measured values for the selected channel sent to an analog output, it may be an advantage to use semi-continuous mode instead; the output value will then always be refreshed at half the measuring rate set - irrespective of the number of measuring points involved.

#### Measured Values

The measured values of 1 to 20 measuring points can be indicated on the display in different menus (that can also be configured) in three font sizes, as bar graph or as line chart. They are automatically acquired with auto zero and self calibration and can also be arbitrarily corrected and scaled as required. A sensor breakage condition is, with most sensors, automatically detected.

#### Analog Output and Scaling

By means of analog start and analog end any measuring point can be scaled so that the resulting measuring range covers the full range of the bar graph or line chart or of an analog output (2V, 10V or 20mA). The measured value of any measuring point as well as a programmed value can be output to the analog output

#### Measuring Functions

Special measuring functions are required for some sensors to achieve an optimal data acquisition. The cold junction compensation is available for thermocouples, a temperature compensation for dynamic pressure and pH and conductivity probes, and an atmospheric air pressure compensation for humidity sensors, dynamic pressure sensors and O<sub>2</sub> sensors. With infrared sensors the parameters zero point and slope correction are used for background temperature and emissivity factor.

#### Max and Min Value

Each measurement involves an acquisition and storage of the Max value and the Min value including the time and date. The values can be displayed, printed or cleared.

#### Average Value

Measured values can be expressed as a sliding average obtained by continuous automatic smoothing or averaged over a particular period or cycle or over a series of individual measuring operations.

### 5.1.3 Process flow control

A continuous measuring point scan with a time-based process flow control for the output of measuring values is required to register the measuring data of all connected sensors. For this purpose, an output cycle is available and, if fast processing is required, the conversation rate is available. The measurement can be started and stopped by using the keyboard, the interface, an external trigger signal, the real time clock or an exceeding of limit values.

#### Time and Date

The real time clock with data function or the pure measuring time are used for an accurate recording of any measurement. Start and end time/date can be programmed in order to start or stop a measurement.

#### Cycle

The Cycle is programmable between 1 s and 59 h, 59 min and 59 s and provides a cyclic output of measured values to the interfaces or memories and also provides a cyclic averaging.

#### Print Cycle Factor

If necessary, the print cycle factor allows for limiting the data output of particular channels so that an excessive data flow can be limited, especially during data storage.

#### Average Value over Measuring Point Scans

The measured values resulting from scanning measuring junctions can be averaged as desired either over the total measuring time or over the cycle time. Function channels are available for a cyclic output and storage of these average values.

#### Conversion Rate

With the ALMEMO® 2690-8 all measuring points can be continuously scanned with the conversion rate (2.5;10 or 50 M/s). To realize a high recording speed it is possible to store all measured values in the memory and/or to perform an output via the interface.

#### Data Memory

During the cycle, all measured values can be manually or automatically stored in an EEPROM. The memory capacity is, as standard, 512 Kilobyte, which allows up to 100.000 measured values. The memory organisation can be configured as linear or ring memory. The output can be carried out via the display or the interface. It is possible to specify a selection according to a time interval or number.

#### Numbering of Measurements

By entering a number, single scans or entire series of measurements can be identified and selectively read out from the memory.

#### Control Outputs

Via keyboard and interface allows to individually trigger up to 4 output relays

and one analog output.

### **Operation**

All measuring and function values can be displayed in different menus on the dot matrix LCD display. 3 user menus can be individually configured from nearly 50 functions for your specific applications. Using texts, lines and blank lines allows to format the printout in an application-specific style. Nine keys (four of them are soft keys) can be used to operate the device. This also allows you to fully program the sensors, the device and the process control.

### **Output**

All data logs, menu functions and stored measured values and programmed parameters can be provided as output to any peripheral equipment. Various interface cables can be used to provide a RS232, RS422, Centronics or Ethernet interface. The output of measuring data can be selected in list format, columns or spreadsheet format. Files in spreadsheet format can be processed by each spreadsheet software. The print header can be programmed specifically to the company or application.

### **Networking**

All ALMEMO® devices can be addressed and can be easily networked by simply linking them using network cables, or RS422 network distributors for longer distances.

### **Software**

The AMR-Control software, which allows for the entire programming of the sensors, the configuration of the measuring instrument, of the user menus and the read-out of the data memory is supplied with each ALMEMO® manual. The integrated terminal also allows for online measurements. The WINDOWS® software WIN-Control is available for data acquisition of networked devices, graphical presentation and complex data processing.

## 6. INITIAL OPERATION

- Sensor connection** Connect transducers to the sockets M0 to M4 (1), s. 8.  
**Power supply** with batteries/accumulators or mains adapter on DC (3) s. 7.1, 7.3  
**Switch-on** Press key **ON/PROG** (6), s. 7.6

Automatical display of the last measuring menu, s. 10.

**Menu selection** **MEAS.-Menus:** call up with key:

e.g. select menu **StandardDisplay**, s. 9.1

Call up the menu with key:

**Select meas. point** (s. 10.1.1) with keys:

Select function **Max/MinVal** (s. 9.4) with:

Clear max/min values, s. 10.1.2

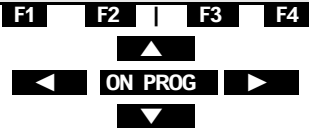

**keys:**

**<ESC>** or **F4**

**▲** / **▼** ... (**F**)

**▶**

**▲** / **▼** ... (**M**)

**PROG**, **▼** ...

**<CLR>** or **F1**

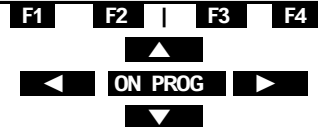
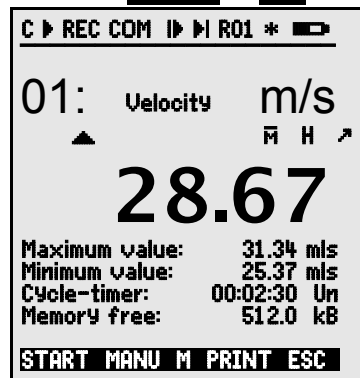

**Output of measuring data or memory via interface:**

- Connect peripheral device, via data cable, to socket A1 (2), s. man. 5.2
- Set 9600bd, 8 data bits, 1 stop bit, no parity at peripheral device

**Single output/storage**, s. 10.3.1

**Cyclic measurement:** Select **Cycle-Timer** :

Enter cycle (hh:mm:ss) s. 9.5

Output format list ' ', columns 'n', table 't'

Stop programming

Start/stop the cyclic measurement, s. 10.3.2

**Output of memory data** to printer or computer:

Select the function **Memory Free** with:

Memory data output, s. 11.2.6

Clear memory, s. 11.2.6

**<MANU>** or **F2**

**PROG**, **▼** ...

**Cycle-Timer: 00:05:00 Sn**

**<FORM>** or **F3** ...

**<ESC>** or **F4**

**<START>**, **<STOP>** or **F1**

**PROG**, **▼** ...

**<PRINT>** or **F3**

**<CMEM>**

## 7. POWER SUPPLY

The following options are available for the power supply of the instrument:

3 alkaline-mignon batteries (type AA) in the extent of the delivery	
Mains adapter 12V, 0.1A with ALMEMO® connector	ZA 1312-NA7
3 NiMH-accumulators (type AA) with charging adapter 12V, 1A	ZA 2690-AS
Electr. isol. power supply cable (10..30V DC, 0.25A)	ZA 2690-UK

Our product line includes corresponding accessories.

### 7.1 Battery operation and Supply Voltage Control

3 mignon batteries are used as the standard power supply of the device. At a current consumption of approx. 30 mA, they last for an operating time of about 100 hours. If the illumination is constantly switched on, this operating period is reduced to approx. 20 to 50 hours (depending on the lightness). To extend the operating time for long term recording it is possible to operate the device in sleep mode (s. 11.2.5). The current operating voltage can be called up in menu **Power supply** (s. 11.7) in order to assess the remaining operating time. When a remaining battery capacity of approx. 10% is reached, the symbol  will be indicated in the status line of the display. If the battery is completely discharged, the device will switch off. However, measuring data and time will be maintained (s. 7.7). To change the batteries, the sensors must be taken off, the rubber protection (7) be removed and the battery cover (8) at the back of the device has to be unscrewed and stripped off in the direction of the arrow.

### 7.2 Accumulator operation

The batteries can also be replaced by 3 NiMH accumulators. In the accessory, there is a corresponding accumulator set with charging adapter (ZA 2690-AS). The accumulators are encoded by stripping so that they can be loaded in the device, batteries are not. As the capacity of the accumulator is only about the half of the alkaline-manganese batteries, the operating times get half as long as well. The charging adapter is to be connected between mains adapter and measuring device. It discerns the maximum current of the mains adapter and correspondingly adjusts the charging time. Maximum current, charging current and charging time can be controlled in the menu **Power supply** (s. 11.7). Operating with accumulator, the stronger mains adapter ZA 1312-NA7 (12V/1.0A) allows an especially fast charging of the accumulators in 2 hours. If the accumulators are completely charged, the charging adapter switches to trickle charge. Therefore, it can stay continuously connected to the measuring device without overcharging the accumulators.



## 7.3 Mains Operation

For external supply of the device the mains adapter ZA 1312-NA7 (12V/1.0A) must be connected to the socket DC (3). Pay attention to the mains voltage! The sensor supply is automatically set to 12V.

## 7.4 External DC Voltage Supply

It is also possible to connect another DC voltage, 6..12V (min. 200mA), to the socket **DC** (3). The connection is performed by using an ALMEMO® connector. However, the electrically isolated supply cable ZA 2690-UK must be used if an electrical isolation between power supply and transducers is required or if a larger input voltage range 10...30V is required. It allows to operate the measuring instrument with 12V or 24V DC on-board supply systems.

## 7.5 Sensor Supply

A configurative sensor supply voltage is provided at the clips – and + in the ALMEMO® connector (self-repairing fuse 500 mA). Instead of the 9V (150mA) as a standard, it is possible to program 6V (200mA) for power saving or 12V (100-mA) if necessary, in the menu **Power Supply** (s. 11.7), according to the demand of the sensors. Other voltages (12V, 15V, 24V or references for potentiometer and strain ganges) are also available with special connectors (s. man. 4.2.5/6).

## 7.6 Switch On/Off, Reinitialisation

To **switch on** the device press the key **ON PROG** (6) in the middle of the cursor block. There always appears the last called up meas. menu first in the display. To **switch off** the device leave a working menu with **<ESC>** and press the soft-key **<P-OFF>** in the menu selection. After switch-off the real time clock continues its operation and all stored data remains available (s. 7.7).

If the device shows an irregular behaviour due to interference influences (e.g. electrostatic charging or battery failure), the device can be reinitialised. The **reset** can be achieved if the key **F1** is pressed during switch-on. If the complete device programming with times, terms of device, user menus etc. is to be set to the delivery defaults, the key **F4** must be pressed during switch-on. Only the sensor programming within the ALMEMO® connectors will not be attached by this reset.

## 7.7 Data buffering

The sensor programming is stored in the EEPROM of the sensor connector, the calibration and the programmed parameter of the device is fail-safe stored in the EEPROM of the device. Time and date are buffered by a lithium battery so that storage of the data is also guaranteed without batteries and when the device is switched off.

## 8. CONNECTION OF THE TRANSDUCERS

Any ALMEMO® sensors can be connected to the ALMEMO® input sockets M0 to M4 of the measuring instrument (1). For connecting existing sensors it is only necessary to connect a corresponding ALMEMO® connector.

### 8.1 Transducers

A detailed description of the comprehensive ALMEMO® sensor range (see manual section 3) and the connection of existing sensors (see manual section 4) to the ALMEMO® instruments are provided in the ALMEMO® manual. All standard sensors with ALMEMO® connector usually have the measuring range and dimension already programmed and can be immediately connected to any input socket. A mechanical coding ensures that sensor and output modules can only be connected to the correct sockets. Furthermore, each ALMEMO® connector has two locking levers that snap in when the insertion into the socket is established and that prevent a disconnection caused by pulling the cable. Both levers must be pressed on the sides for disconnecting the connector.

Especially for the device ALMEMO® 2690-8, new sensors with ready-made ALMEMO® connectors are available. They offer a splash-proof enclosure for the sockets due to their double sealing lips. For unused sockets there are dummy connectors.

### 8.2 Measuring inputs and Additional Channels

The measuring instrument ALMEMO 2690-8 has 5 input sockets (1) that the measuring channels M0 to M4 are initially allocated to. However, ALMEMO® sensors can, if required, provide up to 4 channels so that 20 channels are available with 5 input sockets. The additional channels can be especially used with humidity sensors with 4 measuring variables (temperature/humidity/dew point/mixture ratio) or used for function channels. If required, the sensor can also be programmed with several ranges or scaling or, depending on the pin assignment, 2 or 3 sensors can be combined in one connector (e.g. rH/Ntc, mV/V, mA/V etc.). The additional measuring channels of a connector are increased in steps of 10 (e.g. the first sensor has the channels M0, M10, M20, M30, the second sensor has the channels M1, M11, M21, M31 etc.).

#### Device-internal channels:

An innovation on this device is its four extra additional channels. The first of these M5 is programmed by default as differential channel M1 – M0. This only happens, however, if there are two sensors with the same units and same decimal point position connected at measuring points M0 and M1. However, all four channels can be programmed with any other function channels (e.g. U-Bat, CJ, average, volume flow, etc.); (s. 11.3.10, man. 6.3.4). Mb1 = M1 and Mb2 = M0 are always used as reference channels by default.

**Advantage** of the device-internal channels: If several sensors are being used for the same application, they do not have to be reprogrammed and can be freely exchanged without losing their function channels. If, however, the whole application operates with just one sensor, then programming in the sensor itself makes more sense.

On the measuring instrument this gives the following channel assignment:

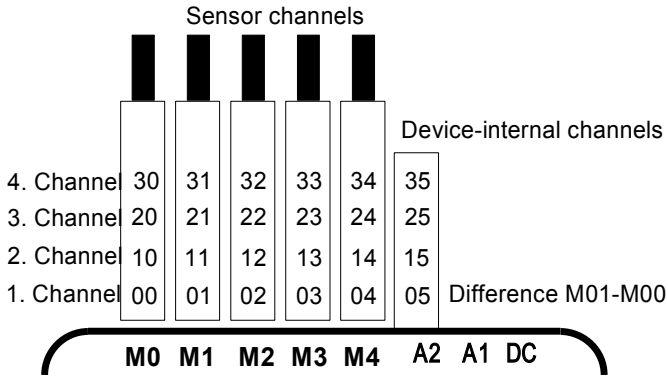

### 8.3 Isolation

When building up a working measuring arrangement, it is very important that there cannot flow any compensation currents between sensors, power supply and peripherals. This is the case when all measuring points are on the same potential or when unequal potentials are electrically isolated.

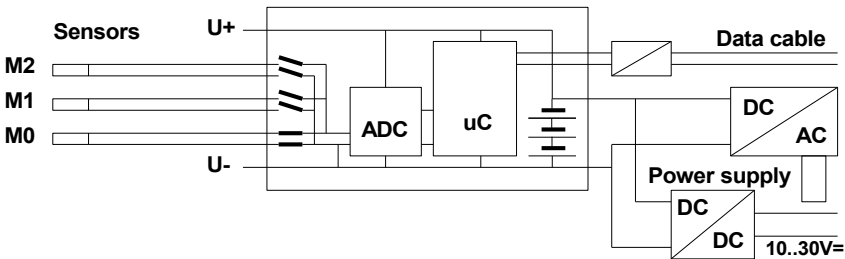

The 5 analog inputs are electrically isolated by photovoltaic relays and between them a potential difference of at most 50 V DC or 60V AC is permitted. However, combined sensors within one connector and sensors with power supply are electrically connected; therefore they must be operated isolatedly. The voltage at the measuring inputs (between B,C,D and A or -) must not exceed 12V! The power supply is isolated by the transformer of the mains adapter or by the DC/DC-converter in the adapter cable ZA2690-UK. Data and trigger cables are equipped with optocouplers. At electrically not isolated cables of the analog output, the registration device or the sensors have to be potential free.

## 9. DISPLAY AND KEYPAD

### 9.1 Display and Menu Selection

The display (5) of the measuring instrument ALMEMO 2690-8 consists of a dot matrix LCD display with 128x128 dots, or 16 lines with 8 dots. For the acquisition of measuring data with the required functions and for the programming of the process control, the sensors and the device parameters, 3 categories of menus are available: Measuring-Menus (s. 10), Programming-Menus (s. 11) and Assistant-Menus, which can be called up over corresponding selecting menus. Of the 9 measuring menus, there are 3 'user' menus U1, U2, U3, which are freely definable by the user (s. 10.7).

* ALMEMO 2690-8 *	* ALMEMO 2690-8 *	* ALMEMO 2690-8 *
<b>MEASURING-Menus:</b> Standard display U1 Meas. value correction U2 Averaging U3 Volume flow Data logger Multi channel display *List of measuring points Bar charts Line diagram  Menu1 PROGRAMMING-Menu Menu2 ASSISTANT-Menus P OFF *ON F MENU1 MEN	<b>PROGRAMMING-Menus:</b> Times, cycles Recording to memory Output from memory Sensor Programming ...Special functions Device configuration Output modules Power supply  Menu1 ASSISTANT-Menu Menu2 MEASURING-Menu P OFF *ON F MENU1 M	<b>ASSISTANT-Menus:</b> Start-Stop Averaging Volume flow Function channels Scaling Sensor adjustment Limits, Alarm Analog output Thermal coefficient Wet bulb globe temperature  Menu1 MEASURING-Menus Menu2 PROGRAMMIER-Menus P OFF *ON F MENU1 MENU2

If necessary, call up the menu selection using the key:

<ESC>

If necessary, select the desired menu selection with key:

<MENU1> o. <MENU2>

Switch on the **Display Lighting** in 3 levels (s. 11.5.5)

<\* ON>

**Switch off** the device with key:

<P-OFF>

or:

ON appr. 4s

Select the menus using the keys:

▲ or ▼ ...

Call up the selected menu with key:

▶ or PROG

Back to the last meas. menu using the key once:

◀

Back to the last programming menu using the key again:

◀

Back to the menu selection with key:

<ESC>



The device designation in the header line can be as easily programmed (s. 11.5.1) as the menu titles of the user menus (s. 10.7).

## 9.2 Function Keys

The function of the keys **F1** to **F4** (6) can be different in the various menus. It is indicated by abbreviations in the bottom line of the display (soft keys). In the manual the soft key abbreviations are set in angle brackets, e.g. **<START>**.

Next to the meas. value, control symbols for the meas.value are displayed (s. below).

The following keys are available in the **Standard display** (s.r.) :

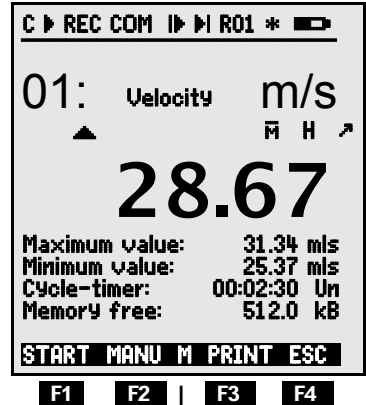

**Selection of measuring points** with the cursor keys (6)

**Starting** a cyclic measurement

**Stopping** a cyclic measurement

Single **manual output**/storage of all measured values

**Output** of menu functions via the interface

**Returning back** to the menu selection

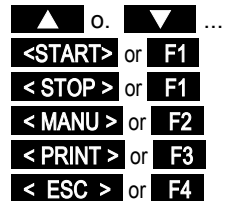

## 9.3 Control Symbols

**Symbols for monitoring the state of the device in the status line:**

Continuous measuring point scan: C

Measurement stopped or started: ii or ►

Measuring point scan started including storing: REC

Measuring point scan started incl. output via interface: COM

Start/end time of measurement is programmed: i► or ►i

Relay status (external output module) off or on: R-- or R01

Display illumination switched on or pause: \* or \*

Batt./accumulator charge state: 100% charged, 50% charged, discharged: flashes

**Symbols for checking the measured value (see above)**

No sensor, measuring point deactivated: '-----'

Measured value altered by sensor correction or scaling: ↗

Averaging in progress: M

Output function altered (s. 11.4.5): D, H, L, M, A

Exceeding of limit value Max or Min: ▲ or ▼ flashes

Exceeding of measuring range: display of max. value O flashes

Undershooting of meas. range: display of min. value U flashes

Sensor breakage sensor voltage Lo :display '-.-.'

Supply voltage too low for measurement: B flashes / L flashes

display switched off

## 9.4 Function Selection

Each menu consists of a number of functions that, possibly, have to be used or programmed during operation.

Help window at function selection:

To set measured value to zero, Press key: ZERO  
To adjust sensor in zero Point (slope) Press key: ADJ

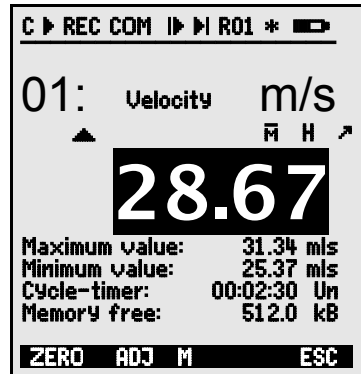

### Selection of the functions.

First changeable parameter is highlighted as inverse coloured font on a black bar:

In the middle of the softkey line appears for control:

Switching to the next function:

Depending on the functions, the keys **F1** or **F3** provide corresponding functions, e.g. MaxValue Clear

Meas. value Set to zero, Meas. value Adjust

Memory data output

Memory Clear

**PROG**

**Velocity**

**F**

**▼** or **▲** ...

**<CLR>**

**<ZERO>** / **<ADJ>** , **PROG**

**<PRINT>**

**<CMEM>**

## 9.5 Data Entry

If a programmable parameter is selected (s. 9.4) you can enter or clear the value.

### Clearing the programmed values

For programming, press the key

Then you are in the **input mode**

the cursor flashes below the first cursor position

**Increasing** the selected number with

**Decreasing** the selected number with

**Changing the sign** of numerical values

**Selecting the next position**

the cursor flashes below the second digit

**Switching back to the previous digit**

**Each digit** is programmed analogously to the first one

**Quitting the data entry**

**Cancelling the programming process**

The input of letters, measuring ranges etc. can be carried out accordingly.

**<CLR>**

**PROG**

**P** in the middle of the softkey line

**Cycle-Timer: 00:00:00**

**▲** ...

**▼** ...

**< +/- >**

**▶**

**Cycle-Timer: 00:00:00**

**◀**

**▲** / **▼** ..., **▶**

**PROG**

**<ESC>**

## 10. MEASURING USING MEASURING-MENUS

After the first switch-on, the device shows the menu **Meas. Points list** (s. 10.5.3). It offers a good overall view over the whole measuring system. This is also where to control, if time and date are right. If not, there is the possibility to program them immediately (s. 9.4 and 9.5). Additionally, you can already see continuously the measured values of all connected sensors and measuring channels. It is even possible to assign extra additional functions like comment, range, max values and limits with the cursor keys **▲** or **▼**. If you program the cycle timer (s. 10.3.2) you can start the first measurement with the key **<START>** and cyclically record the measured values. If a printer or terminal is connected, all values are also put out online. After selecting the channels, it is also possible to program measuring points. To select other measuring menus, press key **<ESC>**.

```

C ▶ REC COM ▶ ▶ R01 * ◀
-----
Meas.Points list: Comment
Time: 12:34:56 Date: 01.01.04
Cycle-timer: 00:00:30 nS
00: 23.12 °C Temperatur
01: 11.37 m/s Velocity
02: 123.4 mV U2.4
10: 53.6 %H r.Humidity
20: 15.2 °C Dew Point
30: 11.2 g/k a.Humidity
-----
START MANU F PRINT ESC
  
```

### Menu selection

The data logger 2690-8 provides a series of prefabricated measuring menus for a best possible display of the measured values and corresponding function values. They are called up in the selection MEASURING-Menus and differ in the number of measuring points (1 to 20), in the display of measured values in different sizes of the digits (4, 8, 12 mm) or as bar or line chart and in the arrangement of functions. If this does not come up to your expectations you can arrange the 3 user menus U1 to U3 yourself from over 50 functions (s. 10.7).

Call up the menu selection with key:

Select a menu with keys:

Call up the selected menu with key:

```

* ALMEMO 2690-8 *
-----
MEASURING-Menus:
Standard display ▶
U1 Meas. value correction
U2 Averaging
U3 Volume flow
Data logger
Multi channel display
*List of measuring Points
Bar charts
Line diagram
-----
Menu1 PROGRAMMING-Menus
Menu2 ASSISTANT-Menus
POFF *ON F MENU1 MENU2
  
```

**<ESC>**

**▲** or **▼** ...

**▶**

The most important functions for controlling the measuring operation are already available in the measuring menus and can be programmed there directly.

For a special programming of the sensors or the device, there are extra **PROGRAMMING -Menus** and for special functions **ASSISTANT -Menus**.

They are selected with the keys:

**<MENU1>** or **<MENU2>**.

## 10.1 Measuring with one Measuring Point

### Standard display

The menu **Standard display** shows a measuring point in the largest display with measuring point, comment and dimension. Some symbols serve for the control of the status of measured values (s. 9.3). The functions maximum and minimum value are described in 10.1.2, cycle timer in 10.3.2 and memory free in 10.3.3.

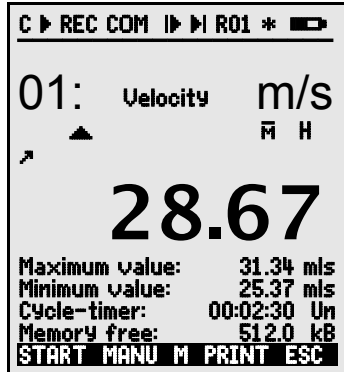

### 10.1.1 Selecting the Measuring Point

The key allows for successively selecting all active meas. points including the display of the current meas. value( **M** in the middle of the softkey line). If the key is pressed, the previous channel is again indicated. By selecting the meas. channel the input channel is, at the same time, also selected.

Increasing the meas. channel using the key:

Decreasing the meas. channel using the key:

### 10.1.2 Peak Value Memory with Time and Date

The highest and lowest value, including the time and date, will each time be determined and stored from the acquired measured values of each measuring point. The functions listed below are available to display these values, function channels are available put them out (s. 11.3.10).

The software AMR-Control can be used to easily load or configure the menu **Monitoring** with Max/Min times (illustrated on the right) as a user menu (s. 10.7).

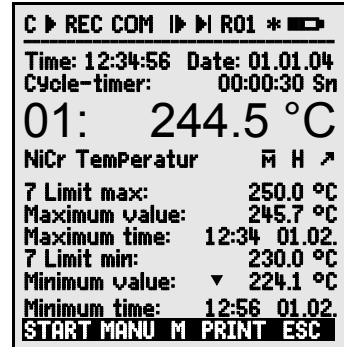

Function Maximum Value:

Function Minimum Value:

Function Time and Date of Maximum Value:

Function Time and Date of Minimum Value:

To clear, select function (s. 9.4):

Clear single value with key:

Clear Max, Min and Avg. Values of all channels:

Due to the continuous measurement the current measured value will be immediately displayed after the clearing process. Furthermore, the peak values are

Maximum Value: 245.7 °C  
 Minimum Value: 224.1 °C  
 Max Time: 12:34 01.02.  
 Min Time: 12:56 01.02.  
 Maximum Value: **245.7** °C



cleared at each start of a measurement, if the device has been correspondingly configured (standard setting, s. 11.5.8).

## 10.2 Correction of the Meas. Value and Compensation

To achieve a maximum accuracy of measurements it is possible to correct the zero point of the sensors in all menus by pushing a button. Additional correction functions are provided in the 'User Menu' **U1 Meas. Correction** (selection s. 9.1). By entering a setpoint the correction value will be automatically calculated and stored in the sensor connector. A corresponding compensation is provided for sensors, which are affected by the ambient temperature or the atmospheric pressure.

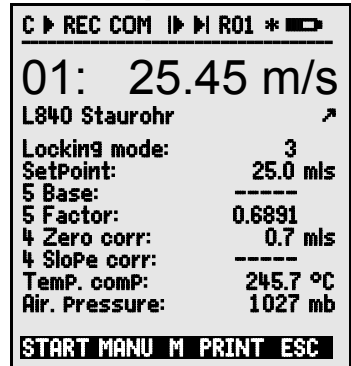

### 10.2.1 Setting the Meas. Value to Zero

The user can zero the measured value at certain locations or at certain times in order to check the deviation from this reference value. After selecting the function Meas. Value (s. 9.4) in any menu, a help window shows you all possibilities of correction of the measured value. The keys **<ZERO>**, **PROG** can be used to store the displayed measured value as base value and, as a result, to set it to zero.

Function select **Measuring Value:**

00: 23.4 °C

Function **Set Measuring Value to Zero:**

**<ZERO>**

Carry out with key:

**PROG**

Measuring Value:

00: 00.0 °C ↗

Base Value:

Base: 23.4 °C

If the function is locked (s. 11.3.4), the base value is not stored in the connector, but only temporarily in the RAM until switch-off.



As long as the deviation from the base value is indicated (instead of the actual measured value) the symbol ↗ appears in the display.

The base value must be cleared in order to re-obtain the actual measured value (s. 11.3.6).

### 10.2.2 Zero Point Adjustment

Many sensors must be adjusted at least once or at regular intervals to compensate for instabilities. For this purpose, a specific **zero point adjustment** is available, in addition to the 'Set Meas. Value to Zero' mentioned above, for not influencing the scaling. In this function the zero point error is not stored as base but as **zero point correction** (s. 11.3.7).

Select function **Measuring Value:**

Function **Zero Point Adjustment** using the key:

Carry out with key:

Meas. Value:

Zero Point:

00: 01.2 °C

<ADJ>

PROG

00: 00.0 °C ↗

Zero Point: 01.2°C

If the function is locked more than 3 (s. 11.3.4), a help box announces that the function can only be unlocked momentarily for adjustment, for a permanent storage of the correction values in the connector.

Sensor ist locked  
-Zero setting temporarily  
Press key: PROG  
-To cancel Press key: ESC

Unlock momentarily for adjustment with key:

<FREE>



If a base value has been programmed, the measured value indicated after adjustment is not zero but the negative base value.



In the case of **dynamic pressure probes** the zero-point error is always written temporarily (i.e. until you switch off) to the calibration offset - even if the channel is locked.

### 10.2.3 Sensor Adjustment in the case of chemical sensors

In the case of the following sensors, with **<ADJ>** (s. 10.2.2), you get automatically from the function measured value to the assistant menu **Sensor adjustment**, for a **two-point adjustment of zero point and slope**. The corresponding calibration value setpoints are already entered, but can also be changed:

Probe:	Type:	Zero Point	Slope
pH probe:	ZA 9610-AKY:	7.00	4.00 pH or 10.00 pH
Conductivity:	FY A641-LF:	0.0	2.77mS/cm
	FY A641-LF2:	0.0	147.0uS/cm
	FY A641-LF3:	0.0	111.8mS/cm
O <sub>2</sub> saturation:	FY A640-O2:	0	101 %

If required, temperature and air pressure can also be entered here for compensation.

**SENSOR ADJUSTMENT**

---

Select measuring channel:  
01: 7.23 PH PH-Value  
Temp.Compensation: 25.0 °C  
Air Pressure 1013. mb

Zero Point:  
Setpoint 1: 7.00 PH  
01: 7.00 PH PH-Value

Slope:  
Setpoint 2: 10.00 PH  
01: 10.00 PH PH-Value

Slope error: -10.8 %

---

START MANU M PRINT ESC

### 1. Setting up a means of calibration for the zero point:

Select function **Setpoint 1**: **SetPoint 1: 07.00 PH**  
**Zero point adjustment** with key: **<ADJ>**  
 The adjustment meas. value is recorded: **00: 07.00 PH ↗**



In the case of pH probes, the standard values, base value 7.00 and slope -0.1689, can be restored by pressing the key **<CLEAR>**.

### 2. Setting up a means of calibration for the slope:

Select function **Setpoint 2**: **SetPoint 2: 10.00 PH**  
**Slope adjustment** with key: **<ADJ>**  
 The adjustment meas. value is recorded: **00: 10.00 PH ↗**  
 The slope shows approximately: **Slope: -0.1689**  
 The **slope error** shows the deviation from the nominal value and therefore the state of the probe: **Slope error: 9 %**



If the sensors are locked, they can be momentarily unlocked by pressing the key **<FREE>**.

## 10.2.4 Two-point Adjustment with Setpoint Entry

In the menu **U1 Meas.Correction** a two-point adjustment is also possible for other sensors. Additionally to the zero point adjustment 10.2.2, the slope can be corrected with a second measuring point using the function **SetPoint**. Pressing a button, the correction factor is automatically determined and stored in the sensor connector.

### 1. Zero point adjustment

Set sensor to the **zero state**  
 (ice water, unpressurized etc.),  
 Set the meas. value to zero by using (s. 10.2.2). **<ZERO>** / **<ADJ>**, **PROG**

### 2. Final value adjustment

Put sensor to a defined **setpoint** **00: 098.7 °C**  
 ((boiling water, known weight etc.)  
 At **ALMEMO force transducers**, switch on/off the calibration resistor  
 (simulation of the control value) (s. man. 3.6.2) with: **<ON>** or **<OFF>**  
 Enter the **setpoint** in function 'Setpoint': **SetPoint: 100.0 °C**  
**Calibrate** the meas. value in function 'Setpoint': **<ADJ>**

Afterwards, the meas. val. should indicate the set point **00: 100.0 °C**



If the sensor is locked with 4 or momentarily unlocked with the key **<FREE>**, the correction factor is programmed as 'factor'. If the locking level is set  $\leq 3$ , the correction factor is programmed as slope correction (s. 11.3.7).

## 10.2.5 Temperature Compensation

Sensors with measured values that are strongly depending on the temperature of the measuring medium are, in most cases, equipped with a specific temperature sensor and the instrument will automatically perform a temperature compensation (s. 11.3.9 measuring range list 'w. PC'). However, dynamic pressure probes and pH probes are also available without a temperature sensor. If the temperature of the medium deviates from 25°C the following measuring errors must be considered:

e.g. error per 10 °C:	Compensation range:	Sensor:
Dyn.press: approx. 1.6%	-50 to 700 °C	NiCr-Ni
pH probe: approx. 3.3%	0 to 100 °C	Ntc or Pt100

Compensation at constant temperature can be activated via the **Temp Comp** (Temperature compensation) function e.g. in the **Meas.Correction** (Measured value correction) menu.

Entering the compensation temperature in the function: **Temp Comp: 31.2°C**

Continuous temperature compensation with external temperature sensors can be activated either via the reference channel of the sensor to be compensated or by configuring any one temperature sensor as reference sensor with "\*T" in its designation; (see 11.3.2).

## 10.2.6 Atmospheric Pressure Compensation

Some measuring variables depend on the environmental atmospheric pressure (s. 11.3.9 measuring range list 'w. PC'). As a result, higher deviations from the normal pressure of 1013mbar can cause corresponding measuring errors:

e.g. error per 100 mbar:	Compensation range:
Rel. humidity psychrometer approx. 2%	500 to 1500 mbar
Mixture ratio, cap. approx. 10%	vapour pressure VP to 8 bar
Dynamic pressure approx. 5%	800 to 1250 mbar (error < 2%)
O <sub>2</sub> saturation approx. 10%	500 to 1500 mbar

Therefore, the atmospheric pressure should be considered (approx. -11mb/100m over mean sea level, MSL) especially during use in a corresponding height above sea level. It can either be programmed (s. 11.5.6) or measured with a reference sensor (reference sensor marked with comment '\*P' s.11.3.2 man. 6.7.2).

The function **Atmospheric Pressure** can be integrated into any user menu or be set in the standard menu **Device Configuration**:

Entering the atm. pressure in function 'Atm. Press.': **AtmPress: 1013. mb**

With each reset the atmospheric pressure is set to 1013mb. It can be set to the current value by the usual data entry (s. 9.5). If it is measured, the measured value will be displayed.



Please note that the last measured value will be retained when a reference sensor is being disconnected.

## 10.2.7 Cold Junction Compensation

Cold junction compensation for thermocouples is normally performed automatically by means of an NTC sensor in measuring socket M2. The Cold junction temperature is displayed as an operating parameter in the device configuration (s. 11.5.8) It can be incorporated if necessary in measured data acquisition as a device temperature with function channel "CJ" (s. 11.3.10) Instead of this form of cold junction temperature measurement it is also possible to use an external measuring sensor (Pt100 or NTC) in an isothermal block (see Manual, section 6.7.3); this must be positioned upstream from the thermocouples and "\*J" must have been programmed in the first two positions in the comments (s. 11.3.2).

For especially exacting requirements (e.g. for thermocouples for which there is no connector with thermo-contacts or for large temperature differences caused by thermal irradiation) there are special connectors available for cold junction compensation each with its own integrated temperature sensor (ZA-9400-FSx). These can be used for all thermocouple types; however, they require two measuring channels. Having "#J" programmed in the first two positions in the comments for the thermocouple ensures that the temperature sensor integrated in the connector is indeed used for cold junction compensation.

## 10.3 Measuring point scans and Output

Measuring point scans can be used to acquire the measured values of all measuring points at particular times, either manually or cyclically over a period of time, which means to store or to record on printer or computer (s. man. 6.5).

For this purpose, the menu **Data logger**, e.g., is available:

```

C ▶ REC COM ▶ ▶ R01 *
Time: 12:34:56 Date: 01.01.04
Cycle timer: 00:00:30 nS
Memory free: 508.3 kB
Number: 01-001 A
01: 244.5 °C
NiCr Temperatur M H ↗
7 Limit max: 250.0 °C
Maximum value: 245.7 °C
7 Limit min: 230.0 °C
Minimum value: ▼ 224.1 °C

START MANU M PRINT ESC

```

### 10.3.1 Single Output / Storage of all Measuring Points

Single manual measuring point scans for acquiring the momentary measured values of all active measuring points (s.man. 6.5.1.1) can be triggered by the key **<MANU>**. If the true time of day has to be indicated, it must first be set (s. 11.1.1). The output format can be set in the function **Cycle Timer** (s. 10.3.2).

#### Single manual measuring point scan:

**<MANU>**

The following symbols will, **for a short period**, be indicated in the **status line**:

The start arrow will light up and then go off again

▶

Lightening up in case of data output via interface

'COM'

Indicated when measured values are being stored (s. 11.1.2)

'REC'

Each time the key is pressed again after this, the measured values are equally processed with the corresponding measuring time.

### 10.3.2 Cyclic Output / Storage of all Measuring Points

For cyclic outputs of measured values (s. man. 6.5.1.2) and recording, the cycle and the output format have to be programmed. The measurement can be **started** by pressing the key **<START>** and **stopped** with the key **<STOP>**. At each start of a measurement the max, min and average values of all measuring points are cleared, if the device has been correspondingly configured (standard setting, s. 11.5.8).

The function **Cycle Timer** indicates the cycle as long as a measurement has not been started. After selecting the function (s. 9.4), the cycle can be entered immediately (s. 9.5). After starting a measurement you can see the timer counting down to the next cycle.

Function **Cycle Timer** :

Cycle Timer: **00:02:00 S**

Cycle (hh:mm:ss), Memory On, Format List

The key **<FORM>** can be used as the quickest way to set the required Output Format (printouts s. man. 6.6.1).

Change format:

**<FORM>**

Format columns next to each other 'n':  
 Change format:  
 Format table 't':

Cycle Timer: 00:02:00\$n  
 <FORM>  
 Cycle Timer: 00:02:00\$st

**Starting a cyclic measuring point scan:**

<START>

For control purposes the following symbols will **continuously**, i.e. for the whole meas.period, be indicated in the **status line**:

The start arrow lights up

▶

Lightening up in case of a data output via interface

COM

Indicated when measured values are being stored (s. 11.1.2)

REC

**Stopping a cyclic measuring point scan :**

<STOP>

||

**10.3.3 Memory space, Memory Output, Clearing the Memory**

The function **MemoryFree** allows, during recording of measuring data, to continuously monitor the available memory space. By selecting this function, two soft keys are available for a direct output and clearing of the memory. The output format corresponds to the setting in the cycle (s. 10.3.2 and 11.1.2)

Function **MemoryFree** e.g.:

MemoryFree: 0378.4 kB

Memory data output (s. 11.2.6):

<PRINT>

Clear memory:

<CMEM>

**10.3.4 Output of Menu Functions**

Each data menu, together with all displayed functions, can be output via interface to a printer or computer (connection of peripheral devices, see manual 5.2). If you have selected the standard display, pressing the key **<PRINT>** leads to a printout of the following listing:

Print data menu:

<PRINT>

Meas. point, meas. value, designation:

01:+0023.5 °C Temperature  
 MAXIMUM: 01:+0020.0 °C  
 MINIMUM: 01:-0010.0 °C  
 PRINTTIMER: 00:01:23

Total memory capacity, free mem. in kB

MEMORY: S0512.1 F0324.4 A

The listing of the individual functions is given in section 6.6.1.

### 10.3.5 Displaying Measured Values as a Line Diagram

When using the menu **Line diagram** the meas. value of the selected channel is indicated as a line chart with 100x200 dots as soon as a measurement is started. The curve continuously moves from the right to the left, the time resolution is determined by the **cycle**, each scan involves one point (dot). Therefore, time data for the whole t axis is given as (days) hours:minutes in the bottom right corner. In the upper right corner the time of day is indicated. In this mode, the curve is also updated during an active measurement, if the user leaves the menu (in this case, do not change the meas. point!).

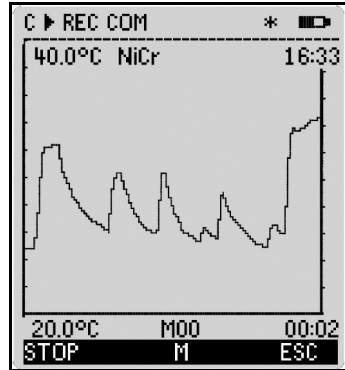

Limits, if activated, are entered as dotted lines.

The functions **Analog Start** and **Analog End** of the menu **Special functions** (s. 11.4.4) can be used to set the display range of the y-axis. They can also be entered directly at the axis using the key **PROG**.

#### Displaying a measured value as line chart:

Enter the cycle in the menu **Times - Cycles**.

Time axis 120 x 5s = 10min:

Select meas. channels using the keys:

Scaling the y-axis with key:

Analog end at the upper end:

Change value (s. 9.5) with the keys:

Analog start at the lower end as above.:

Stop input:

Start measurement:

Stop measurement:

Cycle: 00:00:05  
00:10

▲ or ▼ ...

**PROG**

**PROG**, ▲ / ▼ ..., ▶ ...

▼

**<ESC>**

**<START>** ▶

**<STOP>** ⏏

40.0 %H

20.0 %H



Channel switching is blocked during the measurement!

At each start and at each channel switching the line chart will be cleared!



## 10.4 Averaging

The **average value** of the measured value is required for various applications:

- e.g. Smoothing of a largely varying measured value (wind, pressure etc.).
- The average flow velocity in a ventilating channel.
- Hourly or daily average values of weather data (temp., wind etc.).
- As above, of consumption values (current, water, gas etc.).

The average value  $\bar{M}$  of a measured value results when a number of measured values  $M_i$  are added together and then divided by the number  $N$  of the measured values:

$$\text{Average value } \bar{M} = \left( \sum_i M_i \right) / N$$

There are several different averaging modes in the ALMEMO 2690-8:

Attenuation of measured values of the selected channel with a sliding averaging window, averaging over single measurements of place or time (also as net measurement according to the guidelines from VDE), averaging over the whole measuring time, over cycles or over several measuring points.

You can call up an own assistant menu for all modes to put in the necessary parameters and to learn the operation by help windows.

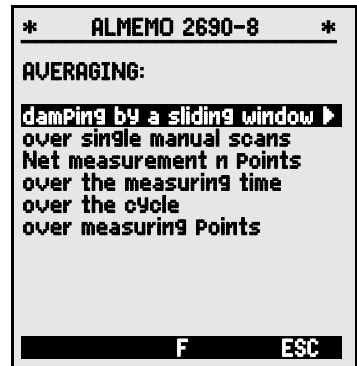

### Measuring menu **Average Value** :

However, most of the averaging functions can also be carried out directly in a measuring menu, e.g. the 'User menu' **U2 Averaging**. The operation of the different modes is explained with help windows during the programming of the averaging mode, e.g.

```

Averaging: CONT
-over whole measurement
with key: START/STOP
-over single manual scans
with key: MANU
  
```

To calculate the volume flow from average velocity and cross-section of a flow conduit, there is a 'User meas. menu' **U3 Volume flow** (s. 10.4.9) as well as a assistant menu **Volume flow**.

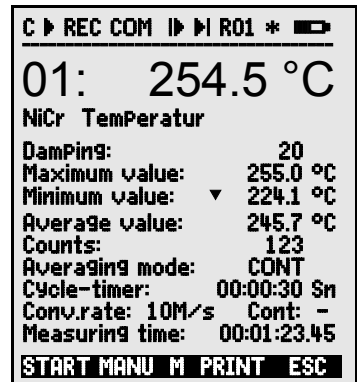

### 10.4.1 Damping of Meas. values by a Sliding averag. window

The first possibility of averaging concerns only the measured value of the indicated channel and helps to damp measured values of an unstable or strongly fluctuating nature, e.g. particular turbulent flows by means of sliding averaging over a time window. The **Level of damping** can be set via the function **Damping** over the number of the respective taken values within the range of 0 to 99. The smoothed measured value also applies for all subsequent evaluation functions. Damping can thus also be used in conjunction with averaging over single measured values (s. 10.4.3) or at net measurements (s. 10.4.4).

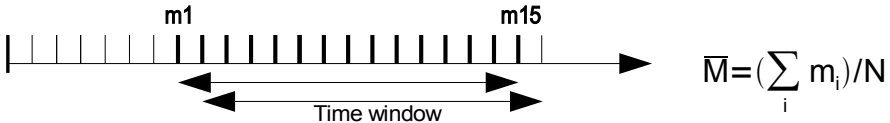

Meas. value damping over e.g. 15 values with: **Damping: 15**  
 Continuous scanning should be switched off,  
 because otherwise the conversion rate would be  
 reduced too much with many measuring points: **Conv.rate: 10M/s Cont: -**

### 10.4.2 Averaging Mode

A detailed description of averaging over measuring point scans is given in the manual section 6.7.4. The type of averaging is determined through the function **Averaging Mode**. With the averaging mode and the corresponding operation the following modes can be set:

Function no averaging: **Averaging Mode: -----**  
 Averaging over single measurements with MANU or  
 all measured values from START to STOP: **CONT**  
 Averaging over all measured values of a cycle: **CYCL**  
 Lightening up for control purposes if averaging is in progress: **M**  
 Display of the average value in the function **Average value 12.34 m/s**



For recording average values a function channel with the range M(t) or the corresponding output function M(t) is required instead of the measured value. (s. 10.5.5).

### 10.4.3 Averaging over Manual Single Measurements

Single manual meas. point scans  $E_i$  are performed for an averaging of isolated measurements at certain points or times. At all measuring points where measured values must be averaged the averaging must be switched on by using the averaging mode 'CONT', a measurement in progress must be stopped.



1. Stop measurement, if it is started: **<STOP>**
2. Set the averaging mode (s. 9.5):  
For smoothing a meas. value select damping: **Averaging mode: CONT**  
Switch the continuous scanning off, if required: **DampIn9: 20**  
**Conv. rate:10M/sCont: E**
3. Clear avg. value by selecting it (s. 9.4) and using: **<CLR>**  
Function 'Average value' displays: **Average val: ----- mls**  
Function 'Counts' displays: **Counts: 00000**
4. Manual scans Ex of single measurements: **<MANU>**  
Function 'Average value' displays: **Average val: 12.34 mls**  
Function 'Counts' displays: **Counts: 00001**
5. Repeat step 4 for each measuring point.
6. Output of all function values of the menu by using: **<PRINT>**

#### 10.4.4 Net Measurement

Especially when determining the average velocity in a flow conduit according to the guidelines VDI/VDE 2640, measurements are to be carried out in a net of individual points in a cross-section which is placed vertically with respect to the flow direction (s. man. 3.5.5). A special menu for net measurements is available to record all single values or to have the possibility to repeat error measurements. It can be selected in the function 'Average value', using the key **<ARRAY>**. The menu can be used for other point measurements, too, of course.

1. The Averaging mode is not important:  
For smoothing a meas. value select damping: **AveragingMode: ----**  
**DampIn9: 20**  
**AverageValue: -----**
2. Select function average value:
3. Select menu net measurement using the key: **<ARRAY>**
4. For data recording, press the key: **PROG**
5. Set the number of points: **Net measurement Points: E**  
A cleared array appears: **01: ---.--- mls**
6. Select a measuring point using the key: **▼** **01: ---.--- mls**
7. Start the measurement with key: **<START>** **01: 11.22 mls**
8. Stop the measurement with key: **<STOP>** **01: 11.43 mls**
9. Record all points according to steps 6 to 8:
10. Clear the array and new measurement with key: **<CLEAR>**
11. Back to the measuring menu: **<ESC>**

```

Net measurement Points: 5
01: 11.43 mls
02: 12.51 mls
03: 19.71 mls
04: ---.--- mls
05: ---.--- mls

Average value: 14.51 mls
STOP CLEAR F ESC

```

### 10.4.5 Averaging over the Measuring Time

To determine the average value of all meas. values, that were acquired over the conversion rate, over a defined period, the averaging mode 'CONT' must be set for the required measuring channel. Averaging can be carried out with or without cycle. A measuring point scan will be performed in any case on start and stop allowing to record the start and end values including the time of day. A function channel  $M(t)$  is required for the recording of the average value  $\bar{M}$  (s. 11.3.9, 11.3.10).

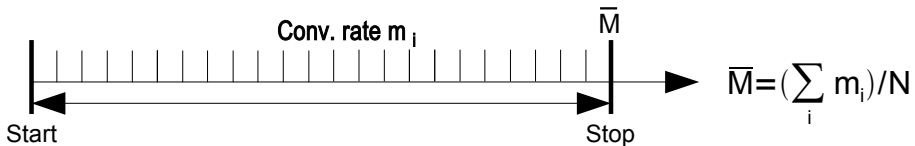

Set the averaging mode:

**Averaging Mode: CONT**

Automatic clearing of average val. on start (s. 11.5.8)

Check:

or, after selecting the average value, by using:

**<CLR>**

Starting the averaging using the key:

**<START>**

▶  $\bar{M}$

Reading the meas. time (s. 10.4.6) in function:

**Meas.Time: 00:01:23.40**

Stopping the averaging using the key:

**<STOP>**

||

Reading the average value in function:

**Average value: 13.24°C**

Output of all function values of the menu by using:

**<PRINT>**

### 10.4.6 Measurement Time, Measuring duration, Timer

For the averaging over time (see above) and for many other measurement experiments, in many cases, the actual measurement time, from start to stop, is required. The function 'Measuring time' has a resolution of 0.10s and is available to allow a continuous monitoring of the measurement time without clearing the real time. If the function 'Clear Meas. Values On Start of a Measurement' is activated within the operating parameters (s. 11.5.8), the measurement time will also be automatically cleared on each start.

Function measuring time:

**Measuring time: 00:00:00.00**

Clearing the measuring time by using:

**<CLR>**

#### Measuring duration

If you want to stop a measuring operation or an averaging process (see above) after a certain length of time, you can program the measuring duration in the menu **Times - Cycles** or in a user menu; (this function is displayed in the status bar with 'M'). (see 10.1.4)

Measuring duration function

**Measuring duration 00:00:00**



Use a programmed measuring duration when recording to memory; this ensures that recording does not abort prematurely.

### Timer as function channel

Measuring times can be output and saved by means of the function channel **Time**; the format is "sssss" or "ssss.s". (see 10.3.9) The resolution can be raised to 0.1 seconds by programming the exponent to -1. At a count of 60000 the timer is reset and starts again at 0. All the normal start / stop functions can be used; in addition, the start, stop, output, and zero-setting of the timer can also be triggered by actions in the event of limit values being exceeded. (see 10.4.3)

### 10.4.7 Averaging over the Cycle

The averaging mode 'CYCL' must be used if average values have to be acquired in cyclic periods over these periods. This ensures, that the average value is cleared after each cycle, but appears in the display during the next cycle.

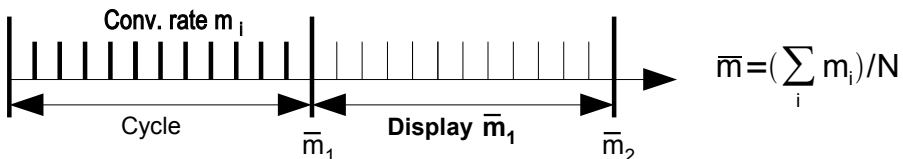

Setting the averaging over cycles:

Programming the cycle (s. 11.1.2):

Start measurement, averaging in progress:

Stop measurement:

Reading the average value/cycle in function:

Output of all function values of the menu by using:

Averaging mode: CYCL

Cycle: 00:15:00

Check:

<START> ▶  $\bar{M}$

<STOP> ||

Average value: 13.24°C

<PRINT>

#### Average value over manual periods:

It is also possible to determine the average value over periods from one manual measuring point scan to the next with the same averaging mode, but without cycle:

Setting the averaging over cycles:

Select and clear cycle using the key:

Averaging mode: CYCL

<CLR>

Cycle timer: 00:00:00

Check:

<START> ▶  $\bar{M}$

<MANU> ▶ ...

Average value: 13.24°C



For recording the average values an additional **function channel** with the range  $M(t)$  (s. 11.3.9, 11.3.10) or the corresponding **output function**  $M(t)$  (s. 11.4.5, man. 6.10.4) is required instead of the measured value.

### 10.4.8 Averaging over several Measuring Points

In all measuring point scans the average value can also be determined over a number of associated measuring points. However, for this average value a function channel with the meas. range M(n) must be available (s. 11.3.9). If you do not wish to program reference channels and the measuring points to be averaged begin with M0, you need simply to program the function channel M(n) to the 2nd channel of the last connector (e.g. M13) (s. 11.3.10). This will then refer automatically to the series from reference channel 2 (M0) through to reference channel 1 (M3 = 1st channel). Other ranges of measuring points can be activated by programming the reference channels accordingly (s. 11.4.6). The function channel can be configured quickly and easily by means of the help menu for **Averaging**.

```

AVERAGING
over range of meas. Points:
From meas. channel :
00: 234.5 °C NiCr
to meas. channel :
03: 189.7 °C NiCr

Program function channel
to channel:
13: 213.7 °C M(n)
Range:                               M(n)

START MANU M PRINT ESC
    
```

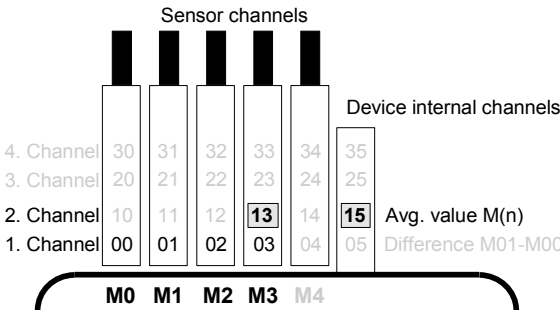

$$\bar{M} = \left( \sum_{i=Bk2}^{n=Bk1} M_i \right) / N$$

Example:

$$M13 = \left( \sum_{i=M0}^{n=M3} M_i \right) / N$$

$$M13 = \bar{M} \text{ from } M0 \text{ to } M3$$

If the sensors are to stay untouched, the function channel can also be programmed to the device internal channels (e.g. M15) (s. 11.3.10). The standard reference channels are here M0 to M1.

## 10.4.9 Volume Flow Measurement

The **volume flow** in flow channels can be calculated by multiplying the average flow velocity  $\bar{v}$  and the cross-section surface. The functions needed for this purpose can be accessed via the 'User menu' U3 **Volume flow** (see on the right); these are a flow channel with averaging, the functions 'diameter' and 'cross-section', and a function channel for volume flow (s. 11.3.10) If the volume flow channel has not yet been programmed or if other functions are needed, e.g. factor or length and width for rectangular cross-sections, please refer to the help menu **Volume flow**.

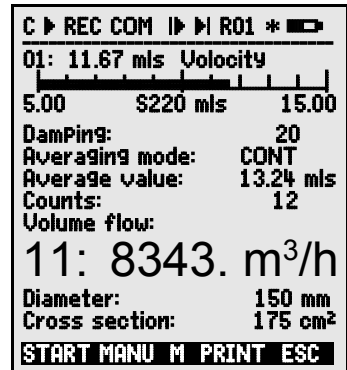

**Volume flow** VF = average flow velocity  $\bar{v}$  · cross section area CS:

$$VF = \bar{v} \cdot CS \cdot 0.36 \quad VF = \text{m}^3/\text{h}, \bar{v} = \text{m/s}, CS = \text{cm}^2$$

For rough air volume measurements at air vents the **average flow velocity**  $\bar{v}$  can be determined by a **time-based averaging** (s. 10.4.5 a. man. 3.5.5). The rotating vane must be applied at one end, the averaging has to be started and it is necessary to proceed uniformly over the whole cross-sectional area and to stop the averaging when the other end of the cross-sectional area is reached. Alternatively, the average flow velocity can also be determined by single **net measurements** according to VDI/VDE 2640 (s. 10.4.4 ) e.g. 13.24 m/s).



To display, output, and / or save the number of measuring operations a special function channel 'n(t)' is available; (see 11.3.9).

With Pitot tubes, in order to calculate actual velocity, both temperature compensation and atmospheric pressure compensation are required; (see 10.2.5, 10.2.6).

The average velocity  $\bar{v}$  is displayed in function:

Input of the diameter in mm (max. 4000):

Input of the cross section area CS directly in cm<sup>2</sup>:

Display of the volume flow VF in a function channel in m<sup>3</sup>/h:

Output of all function values of the menu by using:

Average value: 13.24m/s  
Diameter: 0150 mm  
CrossSection: 0175cm<sup>2</sup>  
Volume flow:  
11: 834.m<sup>3</sup>/h

<PRINT>

### Converting to standard conditions

With all flow sensors it is possible to convert the actual measured values to standard conditions, i.e. temperature = 20°C and atmospheric pressure = 1013 mbar. To do so '#N' must be programmed in the designation either in the speed channel or in the volume flow channel only; (see 11.3.2); this automatically produces the standard volume flow.

## 10.5 Display of Several Measuring Points

The already mentioned measuring menus allow, on principle, only the selection and display of one measuring point. This chapter provides a description on how you can get several measuring points with your selection of functions simultaneously on the display.

### 10.5.1 Menu Multi Channel Display and Bar chart

After the first call the menu **Multi Channel Display** indicates the measured value of the first three active channels in average scale. But they can be programmed as required:

In the menu **Bar Chart** the first four active channels will be displayed with measured value and bar chart:

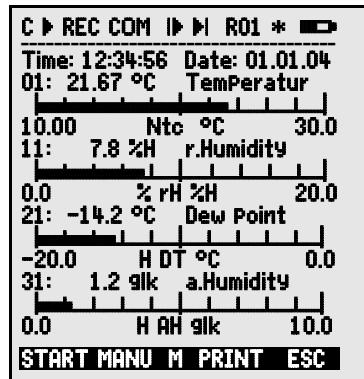
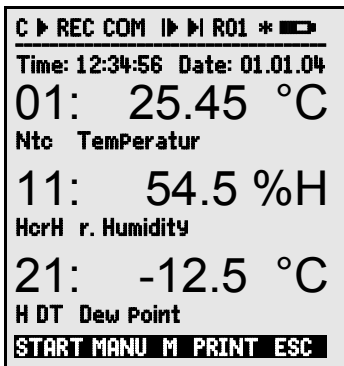

#### Measuring point selection:

The first measuring channel is always the selected measuring point.

This can be selected directly by means of:

To change the other channels, the measuring point

must be selected as function, by means of keys:

The channel can now be changed by means of:

The channel selection is terminated with key:

or ...  
**PROG** and  
 or ...  
**<M>** , **<M>** ...  
**<ESC>**

To **set the display range** for the bar chart the functions "Analog start" and "Analog end" in the **"Special functions"** menu should be used; (see 11.4.4). Having selected these functions they can be entered by pressing **PROG** and or directly on the appropriate axis; (see 9.5).

### 10.5.2 Differential Measurement

If there are two sensors with the same dimensions and same decimal point position connected at measuring points M0 and M1, the difference M1-M0 appears automatically at the device-internal measuring point M5 (s. 8.2). If the differential channel is not required, it must be explicitly deleted (s. 11.3.9). If further differential channels are needed, these can be created using the appropriated reference channels (s. 11.4.6).



### 10.5.3 Menu List of Measuring Points

The best overview of the meas. system incl. all meas. values, time of day, date and cycle is obtained with the menu **Meas.Point list**. From here, it is also possible to get to the **Sensor Programming** of all measuring points.

This menu cannot be individually configured, it can only be combined with some selected functions:

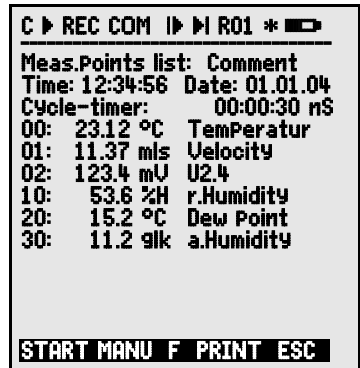

At first call a list with max 20 meas. pts is displayed:

Functions can be allocated to a meas. value with:  
 This reduces the max. number of channels to 10.  
 Select the following function with:  
 Measured value including **comment**:

00: 23.12°C ...  
 ▲ or ▼ ...

Measured value including **maximum value**:

▲  
 MeasValList: Comment  
 00: 23.12°C Temperatur  
 MeasValList: Max value  
 00: 23.12 °C 32.67 °C

Measured value including **minimum value**:

▲  
 MeasValList: Min value  
 00: 23.12 °C 19.34 °C

Measured value including **average value**:

▲  
 MeasValList: Avg. value  
 00: 23.12 °C 25.45 °C

Measured value including **limit value max**:

▲  
 MeasValList: Limit max  
 00: 23.12 °C 32.67 °C

Measured value including **limit value min**:

▲  
 MeasValList: Limit min  
 00: 23.12 °C 19.34 °C

**Measuring range** only (again max. 20 channels):

▲  
 MeasValList: Range  
 00: NTC °C

The programming functions can be accessed as follows:

PROG , ▲ / ▼ ...

## 10.6 Assistant-Menus for Special Meas. Operations

Special measuring operations, i.e. thermal coefficient or wet bulb globe temperature, require a series of sensors in a particular arrangement and function channels programmed for calculating the required variables. To ensure that these two special measuring operations can be performed quickly and easily there is a special assistant menu for each.

### 10.6.1 Thermal Coefficient

To determine the thermal coefficient  $\bar{q}/(T_1 - T_0)$  the two temperature sensors are connected as required (see manual, section 3.2) to channels M0 and M1, and the heat flow plate to M2. The temperature difference  $T(M1) - T(M0)$  is obtained automatically on channel M5.

For this measuring operation the following programming steps are needed :

Averaging mode on M5 : **CONT** or **CYCL**

Averaging mode on M2: **CONT** or **CYCL**

Range on M12: **q/dt**

Enter the cycle by means of: **Cycle timer**

Start measuring by means of: **<START>**

Stop measuring by means of: **<STOP>**

Assistant-Menu  
Thermal Coefficient:

```

Inner temp. T0: Channel: 00
00: 21.67°C NiCr
Outer temp. T1 : Channel: 01
01: 11.42°C NiCr
Difference dt: Channel: 05
05: 10.25°C Diff
Averaging mode: CONT
Heat flow q Channel: 02
02: 103.6 W/m²
Averaging mode: CONT
-----
_Thermal coeff. Channel: 12
12: 193. W/mK q/dt
1 Range: q/dt
Cycle-timer: 00:30:00 Sn
START MANU PRINT ESC
    
```

### 10.6.2 Wet Bulb Globe Temperature

The stress caused in heat-exposed workplaces can be evaluated in terms of their wet bulb globe temperature calculated according to the following formula:

$WBGT = 0.1TT + 0.7HTN + 0.2GT$  (s.man. 3.1.4)

To measure the dry temperature (DT) and the natural humid temperature (HT) a psychrometer (FN A848-WB) with turn-off motor is connected to socket M0 and a Pt100 globe thermometer is connected to socket M1. The output on channel 11 is programmed to WBGT; (for this device the factor 0.2 must not be programmed !).

Assistant-Menu Wet Bulb  
Globe Temperature:

```

WET-BULB-GLOBE-TEMP.
-----
Dry temperature: Channel: 00
00: 21.67°C Ntc
Humid temp: Channel: 10
10: 11.42°C HT
Globe temp: Channel: 01
01: 19.42°C P204
-----
WetbulbGlobetemP: Channel: 11
11: 17.43 °C
1 Range: WBGT
START MANU PRINT ESC
    
```

## 10.7 User Menus

When studying the measurement menus you may have noticed that the display of the meas. value and the combination of functions does not always match your applications in an optimum way. Therefore, you can freely configure the three user menus **U1** to **U3**, in addition to the standard measuring menus using the software AMR-Control. You can use the following list of functions to individually place the functions you require, in any sequence, on your display up to the available space of 13 lines. There is no limit in the number of measuring points, as it is at the ALMEMO® 2590-9. In addition to the meas. functions that have been described before, it is possible to use times and cycles for the process control (s. 11.1.) and most of the sensor programming functions (s. 11.3).

### 10.7.1 Functions

Functions:	Display:	Keys:		Command:
Meas. value small	00: 234.5°C Temperature	ZERO	ADJ	o 15
Meas. value medium 3 lines	00: 1234.5 °C	ZERO	ADJ	o 16
Meas. value large 7 lines	00: Temperature °C  1234.5	ZERO	ADJ	o 17
Meas. value bar chart 2 lines	 5.0      12.20 mls      15.00			o 34
Limit value Max (s. 11.3.5)	Limit Max: 1234.5°C	OFF	ON	o 00
Limit value Min:	Limit Min: -0123.4°C	OFF	ON	o 01
Base value (s. 11.3.6)	Base: -----	OFF	ON	o 02
Factor:	Factor: 1.12345	OFF	ON	o 03
Exponent	Exponent 0	OFF	ON	o 48
Zero point corr. (s. 11.3.7)	Zero correction: -----	OFF	ON	o 04
Slope correction:	Slope correction: -----	OFF	ON	o 05
Analog start (s. 11.4.4)	Analog-start: 0.0°C	OFF	ON	o 06
Analog end:	Analog-end: 100.0°C	OFF	ON	o 07
Range (s. 11.3.9)	Range: NiCr			o 08
Maximum value (s. 10.1.2)	Maximum value: 1122.3°C	CLR	CLRA	o 09
Minimum value:	Minimum value: 19.3°C	CLR	CLRA	o 10
Average value(s. 10.4.5)	Average value: -----	CLR	CLRA	o 11
Cycle (s. 11.1.2)	Cycle: 00:00:00Un	CLR	FORM	o 12
Time, date (s. 11.1.1)	Time:12:34:56 Date:01.02.00	CLR		o 14
Averaging mode (s. 10.4.2)	Averaging mode: CONT	CLR		o 18
Conv. rate: (s. 11.1.3)	Conv.rate: 10M/s Cont: -	OFF	ON	o 19
Cycle Timer: (s. 10.3.2)	Cycle-timer: 00:00:00Un	CLR	FORM	o 20

## 10. Measuring using Measuring-Menus

Averaging Counts (s. 10.4.3)	Counts:	00000.			o 22
Number (s. 11.2.3)	Number:	123-56	OFF	ON	o 23
Range, comment:	NiCr Temperature	M H $\mu$			o 24
Diameter mm (s. 10.4.9)	Diameter:	0000 mm	CLR		o 25
Cross section cm <sup>2</sup> (s. 10.4.9)	Cross-section:	0000 cm <sup>2</sup>	CLR		o 26
Max-time-date (s. 10.1.2)	Max Time:	12:34 01.02.			o 28
Min-time-date	Min Time:	13:45 01.02.			o 29
Blank line:					o 30
Line:					o 31
Smoothing (s. 10.4.1)	DamPing:	10	CLR		o 32
Memory free (s. 10.3.3)	MemoryFree:	502.1kB	CMEM	PRINT	o 33
Device designation(s.11.5.1)	SamPLeMan Corporation		CLR		o 36
)	1: CommentLine		CLR		o 37
Text2:	2: CommentLine		CLR		o 38
ext3: (s. 10.7, Fehler: Referenz	U1 MenuTitle		CLR		o 39
Text4:	U2 MenuTitle		CLR		o 40
Text5:	U3 MenuTitle		CLR		o 41
Locking (s. 11.3.4)	Locking:	5	CLR		o 42
Atm. Pressure (s. 11.5.6)	Atm.Pressure:	1013mb	CLR		o 43
10.2.5)	Temp.comPens.:	25.0°C	CLR		o 44
Setpoint (s. 10.2.4)	SetPoint:	1100.0°C	OFF	ADJ	o 45
Meas. time: (s. 10.4.6)	Meas. Time:	00:00:00.00	CLR		o 46
Meas. duration	Meas. duration	00:00:00	CLR		o 47
End of menu:					o 99

### 10.7.2 Configuration of the menus

Select one user menu **U1**, **U2** or **U3** from the

**MEAS.Menus:**

measuring menus you do not need at the moment:



Please connect the device for configuration via data cable with your PC and call up the delivered

#### Software AMR-Control.

With one click on: Network scanning you get to the: Device list

Select the device and press: Program user menus

Pull the functions from the left side to the menu window on the right with the drag and drop function.

 At all functions containing a measured value (e.g. max, average value, also bar display) you have to put in the measured value of the measuring point first, afterwards the corresponding functions!

Put in an expressive menu title: User menu title

Store the finished menu in the device on Ux with: Menu store, Ux, OK

All menus can also be stored in the PC and be reloaded, if required!

### 10.7.3 Function Printouts

The functions of all measurement menus can be printed out in the listed sequence by using the key: **<PRINT>** (s.a. 9.3.4)  
The print format of the individual functions is given in the following table:

<b>Funktion</b>	<b>Ausdruck</b>	<b>Befehl</b>
Meas. Values all	01: +0023.5 °C Temperatur	P35
Maximum Value	MAXIMUM: 01: +0020.0 °C	P02
Maximum Time	MAX-TIME: 01: 12:32 01.02	P28
Minimum	MINIMUM: 01: -0010.0 °C	P03
Minimum Time	MIN-TIME: 01: 12:32 01.02	P29
Average Value	AVERAGE VAL.:01: +0017.8 °C	P14
Averaging Mode	AVERAGEMODE: 01: CONT	P21
Averaging Count	AVERAGECOUNT:01: 00178.	P22
Memory Free	MEMORY: S0512.1 F0324.4 A	P33
Number	NUMBER: 01-012	P23
Range (Comment)	RANGE: 01: NiCr	P24
Limit Max	LIMIT MAX: 01: -0100.0 °C	P08
Limit Min	LIMIT MIN: 01: +0020.0 °C	P09
Base	BASE: 01: -0273.0 °C	P06
Factor	FACTOR: 01: +1.0350E-1	P07
Zero Point Correction	ZERO CORR: 01: -0000.7 °C	f1 P06
Slope Correction	SLOPE CORR: 01: +1.0013	f1 P07
Analog-Start	ANALOG START:01: +0000.0 °C	P16
Analog-End	ANALOG END: 01: +0100.0 °C	P17
Cycle	PRINT CYCLE: 00:06:00	P11
Cycle-Timer	PRINT TIMER: 00:06:00	f1 P11
Time, Date	TIME: 12:34:00 01.02.04	P10, P13
Start Time	START TIME: 07:00:00	f1 P10
End Time	END TIME: 17:00:00	f2 P10
Start Date	START DATE: 01.02.04	f1 P13
End Date	END DATE: 02.02.04	f2 P13
Measuring Time	MEASURETIME: 00:00:00.00	P46
Meas. duration	MEAS. DURATION 00:00:00	P47
Damping	DAMPING: 01: 10	P32
Diameter	DIAMETER: 01: 00100 mm	P25
Cross section	CROSS SECT: 01: 00078 cm2	P26
Atm. pressure	A.PRESSURE:+01013.mb	P43
Temp. compensation	COMPENSATION:01: 25.0°C	P44
Setpoint	SET POINT: 01: 1100.0°C	P45
Device designation	Fa.Ahlborn,Holzkirchen	P36
Line	-----	P31
Blank line		P30
Text1	Comment Text 1	P37
Text2	Comment Text 2	P38
Text3	Menu Title U1	P39
Text4	Menu Title U2	P40
Text5	Menu Title U3	P41
Locking	LOCKING MODE: 5	P42

## 11. PROGRAMMING WITH PROGRAMMING-MENUS

Apart from the measuring functions you have already get to know some functions for process control and sensor programming in the measuring menus.

Here in the **PROGRAMMING Menus** you find a complete and systematic list of all programming functions.

From the measuring menu, you reach the selection menu using the key: **<MENU1>**

For some programming function, there are additional **ASSISTANT Menus**.



### 11.1 Times and Cycles

All time functions for measurement, process control and recording are combined in the programming menu **Times - Cycles** and can also be programmed there.

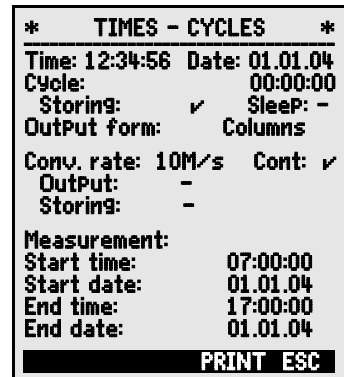

#### 11.1.1 Time and Date

The ALMEMO 2690-8 is equipped with a real time clock with date function for recording the measuring time. It has a lithium battery so the time and date are also maintained after battery change. By selecting the function (s. 9.4) the time can be programmed in the specified format in the first line on the left side and the date on the right side (s. 9.5).

**Function Time and Date:**

**Time: 12:34:56 Date: 01.05.00**

Format of time and date:

hh:mm:ss dd.mm.yy

#### 11.1.2 Cycle with Storage Activation and Output Format

The **Cycle** is used for cyclic storage and outputs of measuring data on the interface (it corresponds to the print cycle of other ALMEMO® devices, the measuring cycle is no longer implemented). The storage activation in the cycle, i.e. the cyclic recording of data in the memory is automatically switched on after a reinitialisation but it can also be switched off, if required.

The **output format** (see manual 6.6.1) determines the print format at measuring point scans and at the memory output. It is programmed by using the function **Output form**. Apart from the standard format 'List' with all measured values given in a list, the output format 'Columns' allows for a clear and space-saving printout in columns. For this purpose, a printer will automatically switch to the condensed character mode. The **format** 'Table' is available to further process measuring data by means of spreadsheet applications (s. print images man. 6.1).

Function <b>Cycle</b> (format hh:mm:ss):	<b>Cycle:</b> 00:15:00
Clear cycle, terminate current scan:	<b>&lt;CLR&gt;</b>
Function <b>Storage activation in cycle</b> :	<b>Storing:</b> <input type="checkbox"/> normal: -
Switch on storing (basic setting):	<b>&lt;ON&gt;</b> <input checked="" type="checkbox"/>
Switch off storing:	<b>&lt;OFF&gt;</b> -
Switch on function <b>sleepmode</b> s. 11.2.5:	<b>&lt;ON&gt;</b> <b>Sleep:</b> <input checked="" type="checkbox"/>
<b>Output format</b> 'l' measured values in list format:	<b>Output form:</b> List
Output format 'n' columns side by side:	<b>Output form:</b> Columns
Output format 't' table with semicolon separation:	<b>Output form:</b> Table
In the meas. menus the format abbreviations 'n' or 't' and 'S' (with storage activation) or 'U' (without storage activation) are displayed next to the cycle :	<b>Cycle:</b> 00:15:00 \$n

### 11.1.3 Conversion Rate, Continuous Measuring Point Scan

If required, for measuring point scans the conversion rate can in function **Conv. rate** be increased from 2,5 up to 10, 50 or 100M/sec (s. man. 6.5). There is also an option (SA0000-Q4) for setting the measuring rate to 400 mops but this is only possible for 1 measuring channel at a time.

#### Half-continuous measuring point scan

The possibility to record only the selected measuring point (not continuous) is not intended anymore, because errors are easily made when corresponding sensors are not recorded. However, it can be useful, especially with many sensors, to treat the selected measuring point in a favoured way and to replace the measured value once in a while, e.g. at analog output or smoothing of the measured value. Therefore, by default the not continuous meas. point scan was replaced by the **half-continuous meas. point scan**, i.e. all measuring points are continuously recorded, but every second measurement records the selected measuring point.

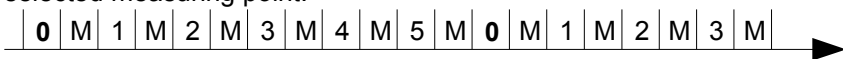

#### Continuous measuring point scan

If the **continuous measuring point scan** is switched on, all active measuring

## 11. Programming With Programming-Menus

channels will be continuously and successively scanned by the conversion rate and all measured values are always up-to-date (s. man. 6.5.1.3). This doubles the total sampling rate. In both modes all measured values can be saved and / or output at any time.

The continuous storage and the continuous output of the measured values can be activated with the conversion rate using the following two functions.

<b>Function Conversion rate:</b> Input s. 9.5	<b>Conv. rate:</b> 10M/s
half-continuous measuring point scan (basic setting):	<OFF> Cont: <input type="checkbox"/>
continuous measuring point scan:	<ON> Cont: <input checked="" type="checkbox"/>
continuous storage off:	Storing: <input type="checkbox"/>
activate continuous storage:	<ON> <input checked="" type="checkbox"/>
continuous output off:	Output: -
activate continuous output:	<ON> <input checked="" type="checkbox"/>



It should be noted, however, when selecting the measuring rate, that the higher the measuring rate so the lower the measuring quality and, conversely, the lower the rate, the higher the quality.

At measuring rates above 10 mops (measuring operations per second) mains hum suppression is not possible; as a result accuracy may be adversely affected by interference over the connection lines; (wherever possible use twisted wires).

At 100 or 400mops saving to memory is only possible with the multimedia card but not with the internal EEPROM.

### 11.1.4 Time and Date of Start, Time and Date of End

A sequence of measurements can, at certain points in time, be automatically started and stopped. For this purpose the start time and date and the end time and date can be programmed. If a date has not been specified the measurement will be performed every day in the defined period. The current time must be programmed beforehand. Or, alternatively, instead of specifying the end time-of-day the measuring duration itself can be programmed. (s 9.4.6; 10.2.2)

<b>Function Start Time</b> (format hh:mm:ss):	<b>Start time:</b> 07:00:00
<b>Function End Time</b> (format hh:mm:ss):	<b>End time:</b> -----
<b>Function Start Date</b> (format dd:mm:yy):	<b>Start date:</b> 01.05.00
<b>Function End Date</b> (format dd:mm:yy):	<b>End date:</b> -----

To clear values, select function and then use:

<CLR>

If the start time of a measurement has been programmed, the status line will show the symbol:

▶

If the end time of a measurement or Meas. duration

has been programmed, the status line will show the symbol:

▶▶



## 11.2 Data Memory

The basic information with regard to data storage in ALMEMO® devices is given in the manual section 6.9. The internal data memory of the ALMEMO 2690-8 is a 512kByte EEPROM with capacity sufficient for 64.000 to 100.000 measured values (depending on the channel number). In the event of a failure in the supply voltage the measured data is retained. The EEPROM can be configured either as linear memory or ring memory (s. man. 6.10.13.2).

### 11.2.1 Memory connector with SD card

If memory capacity proves insufficient or if the data needs to be evaluated elsewhere, you can, as additional external memory, use a memory connector (ZA 1904-SD) with a conventional SD card, available from our range of accessories. The measured data is written to it via the memory connector in table mode and in standard FAT16 format. The SD card can be formatted and its contents can be read and deleted via any normal PC using any card reader. Measured data can be imported into MS-Excel or into the accompanying measured value software Win-Control.

The memory connector with the additional memory card can be connected at socket A2; it is recognized automatically. You can see that it is properly connected in menu **Record to memory** in the function **External memory**, by the higher memory capacity, and a file name in the function **File name**. (s.10.3.1 )

If the external memory is connected at the start of any measuring operation, it will be used. In the course of the measuring operation it must not be unplugged; this would cause temporarily buffered measured values to be lost.

External memory capacity available	<b>External memory</b>	<b>64.00 MB</b>
Memory capacity still free	<b>Memory free</b>	<b>21.75 MB</b>
File name (maximum 8 characters)	<b>File name</b>	<b>ALMEMO.001</b>

In the function **File name**, before starting any measuring operation, you can enter an 8-character file name. In the absence of a user-assigned file name, the default name "ALMEMO.001" or the name most recently used will be provided automatically. So long as the connector configuration is not altered, you can save several measuring operations, either manual or cyclic, even with numbers, in the same file. (s. 10.3.2) If, however, the **connector configuration has been changed** since the most recent measuring operation and if no new file name has been programmed, then a new file is always created and in so doing the index in the file name extension is automatically incremented by 1, e.g. "ALMEMO.002". Similarly, if the file name entered already exists, then a new file will be created with the same file name prefix but with a new index.

To check that the memory connector is **functioning properly** there is an LED incorporated in the end of the handle; this indicates the following states :

- No memory card detected : LED flashes once long and then three times short.
- Data is being recorded : LED flashes in the same rhythm as the cycle.

- Data is being read out : LED lights up continuously for the duration of data output



When plugging in the connector make sure that the card remains latched in position !

The ring memory mode is not supported by memory cards

## 11.2.2 Data Acquisition

Most of the parameters, which are required for the **recording** of measuring data, have already been described in the menu **Times - Cycles** (s. 11.1).

1. Time and date
2. Cycle, storage activation, sleep mode
3. Conversion rate with storage activation
4. Time of start and end of a measurement

The menu **Recording to memory** can be used for an especially simple recording to memory.

Additionally, there are extra assistant menus for the various possibilities to start and stop the measurement! (s. 11.2.4)

**Attention:** One sensor configuration is only stored during the first start, additional sensors are completed at the next start. If other sensors are connected, memory must be readout and cleared before the next recording!

Menu **Recording to memory** :

Internally available memory capacity:

Available free memory space:

**Linear memory** without overwriting of data:

Activate **ring memory** with overwriting of data:

Nb of act. channels to calculate the storing time:

Input of **cycle** (s. 9.5, format hh:mm:ss):

**Minimal cycle** with 50M/s corresp. to active channel:

Cycle without storing and without sleepmode:

Select and switch on **storing** using the key:

Switch on **sleepmode** (s. 11.2.5) using the key:

**Storing time** from cycle and channel number:

**Meas.duration**, after start automatic stop after:

**Number**: e.g. room 12, meas. point 1 s. 11.2.3

* RECORDING TO MEMORY *	
Memory internal:	512.0 kB
Memory free:	125.8 kB
Ring memory:	<input checked="" type="checkbox"/>
Meas.channels: 24	active: 05
Cycle:	00:01:00.00
Storing:	<input checked="" type="checkbox"/> Sleep: -
Storing time:	24d 13h
Meas. duration:	00:01:00
Number:	01-001 A
PRINT ESC	

Memory internal: 512.0 kB

Memory free: 217.5 kB

Ring memory: -

**<ON>**

Meas.chann: 24 active: 05

Cycle: 00:01:00

**<MIN>** 00:00:00.12

Storing: - normal: -

**<ON>**  normal: -

**PROG**  **PROG** Sleep:

StoringTime: 24d 13h

Meas.duration: 00:10:00

Number: 12-001 A

### 11.2.3 Numbering of measurements

For the identification of measurements or series of measurements it is possible to individually enter a number before starting. With the next measuring point scan it will be output or stored, respectively. This allows to also assign single measurements during a read-out to specific measurement locations or measuring points (s. manual 6.7).

After selecting the function **Number** the 6-digit number is entered in the usual way (s. 9.5). In addition to the figures 0 to 9 the characters A,F,N,P,- or \_ (space) can be used. After the input the number is activated and next to it an 'A' will be indicated until the next cyclic or manual measurement will be stored.

Function **Number**: (e.g. room 12, meas. point 1)

NUMBER: [2-00] A

**Zero setting** and deactivating the number with key:

<CLR>

**Activating** and **deactivating** the number with key:

<ON>, <OFF>

Incrementing and **activating** the number with:

<+1>

### 11.2.4 Starting and Stopping of measurements

Additionally to starting and stopping of the measurement with the keys, there are even more possibilities, concretely conveyed by the assistant menu **START-STOP**.

The operation via interface is described in the manual section 6.6.

The function of start time and end time is described here in section 11.1.4, the limit value responses in section 11.4.3 and the varieties of relays and trigger in section 11.6.2.



### 11.2.5 Scanning mode

For autonomous operation and / or for scanning by computer there are 4 scanning modes available.

**Normal** Internal cycle or cyclic scanning by the computer

**Sleep** Internal cycle only, automatically switching off for long-term monitoring

**Monitor** Internal cycle, not disturbed by computer scanning

**Fail-safe** Cyclic scanning by the PC after any failure the internal cycle

**Sleepmodus**

For long term monitoring with larger cycles it is possible to operate the measuring device in sleep mode. Within this power saving mode the device will be switched off after each measuring point scan (this is to be considered using sensors with power supply!) and will be automatically switched on for the next measuring point scan after the cycle time has expired. This procedure allows, with one set of battery/accumulators to perform more than 15000 measuring

point scans. At 10 minutes for one cycle this results in a total measuring time of more than 100 days.

The following steps must be carried out in the menu **Recording to memory** to perform a **data recording in the sleep mode**:

- |  |   |
|--|---|
| <ol style="list-style-type: none"> <li>1. Enter a cycle with a min. duration of 2 minutes:</li> <li>2. Switch on the storage activation in the cycle:</li> <li>3. Select the sleep mode:</li> <li>4. Switch on the sleep mode using the key:</li> <li>5. Start the measurement in a meas. menu with key:<br/>The device announces in the display,<br/>then it switches off, for control purposes only a<br/>red lamp flashes regularly on the upper window<br/>frame.</li> <li>6. Within the set cycle the device switches automatically on, performs a measuring point scan, and then switches off again.</li> <li>7. Terminate sleep mode using the key:</li> <li>8. Terminate measurement using the key:</li> </ol> | <div style="background-color: #e0e0e0; padding: 2px; margin-bottom: 5px;"><b>Recording to memory</b></div> <p><b>Cycle:</b> 00:05:00</p> <p><b>Storing:</b> <input checked="" type="checkbox"/> normal: -</p> <p><b>Storing:</b> <input checked="" type="checkbox"/> normal: <input type="checkbox"/></p> <p><b>PROG</b> <input type="checkbox"/> <b>PROG</b> <b>Sleep:</b> <input checked="" type="checkbox"/></p> <p><b>&lt;START&gt;</b></p> <p><b>Sleep On</b></p> <p>LED 'SLEEP' (4) flashes</p> <p><b>&lt;ON&gt;</b></p> <p><b>&lt;STOP&gt;</b></p> |
|--|---|



The start or stop through start and end time or through limit values is, on principle, not possible in sleep mode and, therefore, must be switched off!

### Monitor mode

This new "monitor mode" should be used when a data logger, being operated on a cyclic basis, is to be monitored occasionally by computer. Internal cyclic scanning is not influenced in any way by software scanning; (in Win-Control "safe initialization" must be switched off). The internal cycle is started as and when the software starts; it may also have been started previously. Scanning via the internal cycle does not cause any data to be output to the interface. In order to record data the memory must have been activated.

In the Mode function the Monitor variant must be programmed **Monitor mode**

### Fail-safe mode

The "fail-safe mode" is suitable when scanning is purely software-based and merely ensures that scanning will, in the event of computer failure, continue on an internal cyclic basis. In this mode the cycle programmed in the device must be larger than that needed for software scanning. Software scanning keeps resetting the internal cycle with the effect that this cycle is only actually used as and when software scanning fails; (in Win-Control "safe initialization" must be switched off). The internal cycle is started as and when the Win-Control software starts; it may also have been started previously. Scanning via the internal cycle does not cause any data to be output to the interface. In order to record data the memory must have been activated.

In the Mode function the Fail-safe variant must be programmed **Mode: Fail-safe**

## 11.2.6 Memory Output

The content of the data memory can, completely or in parts, be output to the serial interface. For each output one of the three available output formats 'List', 'Columns' or 'Table' can be used. The option to specify partial ranges is available as it is possible to set the start and end time of measurements and also possible to select the number of corresponding identified measurements.



With **external SD memory cards** (see 10.2.1) there is only one option available, namely output in table

mode of all the measured data contained in the file most recently used. For this purpose simply press the key **PRINT** in the function **Memory free** in the menu **Memory output** or in certain measuring menus. The most sensible approach is to remove the memory card and copy the files via a USB card reader directly onto the PC. These can then be imported either into MS-Excel or into Win-Control (as of V.4.8.1).

Menu **Memory Output** :

Setting the **output format**:

In case of **selecting a numbered measurement**:

In Function **Number** select number with keys:

To **select a time interval**:

Enter the start time using the format 'hh:mm:ss':

Enter the end time using the format 'hh:mm:ss':

Enter the start date using the format 'dd:mm.yy':

Enter the end date using the format 'dd:mm.yy':

Perform complete output of data memory:

Output of a numbered measurement:

Output of a time interval from start to end:

Cancelling the memory output using the key:

The internal memory contents will be output with the same print format as with a printer operation, including multiple printouts and different formats (not Memory cards)(s. man. 6.6.1).

During the output of data memory, the remaining memory content (in kB) to be output is continuously indicated in the function **Residual output** . Time, date and number show the current values .

Remaining memory output:

current number of memory output:

current time and date of memory output:

* OUTPUT FROM MEMORY *	
Memory Internal:	512.0 kB
Memory free:	125.8 kB
Residual output:	12.5 kB
Output form:	Columns
Number:	01-001 A
Time: 12:34:56	Date: 01.01.04
Time interval:	
Start time:	07:00:00
Start date:	01.01.04
End time:	17:00:00
End date:	01.01.04
<b>ALL NR F TIME ESC</b>	

Output form: List

NUMBER: 12-001 A

<FIRST>, <NEXT> ..., <LAST>

Start time: 07:00:00

End time: 17:00:00

Start date: 01.05.00

End date: 01.05.00

<ALL>

<NR>

<TIME>

<STOP>

Residual output: 12.5 kB

Number: 01-001A

Time: 12:34:56 Date: 01.01.04

### Clear memory

Select function **Memory free** (s. 9.4):

To clear the memory, press the key:

Full memory capacity is indicated in function:

Cancel by using the key:

**Memory free:** 384.5kB

**<CMEM>**

**Memory free:** 512.0kB

**<ESC>**

## 11.3 Sensor Programming

As all ALMEMO® instruments contain the whole sensor programming stored in the ALMEMO® connector plug, the user, usually, does not need to perform any programming. Only if, for example, sensor errors must be corrected or existing sensors must be scaled or limit values need to be specified the comprehensive programming options have to be used.

If the corresponding sensor connector is connected all parameters of a channel can be checked and entered or changed via keypad in the menu **SENSOR PROGRAMMING**. It must be considered that standard sensors are, by a locking mode, protected against unintentional modification and that the locking level must first be reduced before desired changes can be performed (s. 11.3.4). The functions are only selectable as far as the locking mode allows, the rest appears in grey.

Output of the sensor programming of all active measuring points (command P15 s. man. 6.2.3) with key:

```

* SENSOR PROGRAMMING *
Connector: 0 Channel: 00
Comment:      Temperatur
Averaging mode:  CONT
Locking mode:  5
7 Limit max:   35.0 °C
7 Limit min:   -----
5 Base:        -----
5 Factor:      -----
5 Exponent:    0
4 Zero correct: -----
4 Slope correct: -----
2 Dimension:   °C
1 Range:      NiCr
MALL M PRINT ESC
    
```

**<PRINT>**

### 11.3.1 Selecting the Input Channel

To query or to program the parameters of a sensor, it is first necessary to select the menu **SENSOR PROGRAMMING** and then to set the required input channel by using the key **▲** or **▼**. For this, only connected sensors and activated channels will be considered. To be able to activate new channels, the key **<MALL>** can be used to enable the selection of **all** channels. The key **<MACT>** can be used to reduce the selection back to the **active** channels only. The corresponding connector number will be displayed with each input channel.

Menu **SENSOR PROGRAMMING** :

Indication of connector number and channel:

Selecting the next input channel using the key:

Selecting the previous input channel using the key:

Enabling the selection of all available channels:

Reducing the selection to all active channels:

**Connector:0 Channel:00**

**▲**  
**▼**

**<MALL>**

**<MACT>**

### 11.3.2 Measuring Point Designation

Each measuring point can be given a 10-digit alphanumeric designation to optimally identify the type of sensor, the measuring location or the purpose of the application. This comment will be indicated with all standard displays of measured values. If it has not been programmed, the abbreviation of the measuring range will be indicated. In case of outputs via interface the measuring point designation appears in the program header as 'COMMENT' and in the list of measured values (see man. 6.6.1).

Input in function 'Comment' s. 9.5

**Comment: Humidity**

Certain control characters at the beginning of the designation have special functions.

'\*J' This defines a temperature sensor (NTC, Pt100) as reference for external cold junction compensation; (see 10.2.7 and Manual 6.7.3).

'#J' This means that an internal cold junction sensor is to be used for a thermocouple (e.g. connector ZA9400-FSx with NTC); (see 10.2.7 and Man. 6.7.3).

'\*T' This defines a temperature sensor (NTC, Pt100) as reference for temperature compensation;

'\*P' This defines an atmospheric pressure sensor as reference for atmospheric pressure compensation;

'#N' This activates conversion to standard conditions for flow measuring;(s 10.4.9).

The remaining 8 characters can be used for the user's own descriptions.

'!' at the end automatically indicates internal linearization or calibration; (see 10.3.10). This cannot be overwritten.

### 11.3.3 Averaging Mode

The types of averaging, which are defined through the function **Averaging mode** are described in section 10.4.2.

Function no averaging:

**Averaging mode: -----**

Averaging over all running measuring point scans:

**CONT**

Averaging over all scans in one cycle:

**CYCL**

### 11.3.4 Locking the Programming of the Sensor

The function parameters of each measuring point are protected by the locking mode up to an adjustable locking level. Before any programming is performed the locking mode must be correspondingly lowered. If a dot is indicated following the locking mode on the display then a modification is not possible.

**Locking Level**

**Locked Functions**

0	none
1	Meas.range + element flags + output mode
3	+ Dimension
4	+ Zero point and slope correction
5	+ Base value, factor, exponent
6	+ Analog output start and end, Zero point correction temporarily
7	+ Limit values, max and min

Function 'LockingMode':

**Locking: 5**

In the menu **SENSOR PROGRAMMING** the functions are arranged from top to bottom so that the locked functions cannot be selected.

### 11.3.5 Limit Values

Two limit values (MAX, MIN) can be programmed and allocated to each measuring channel. An exceeding of limit values is handled as a fault, similar to an exceeding of meas. range limits and sensor breakage. On the display a corresponding arrow ▲ or ▼ will appear next to the measured value and the alarm relays of a connected relay cable will respond (s. 11.6.2). Relays can also be assigned to limit values (s. 11.4.3). The alarm condition will persist until the measured value has dropped below the limit value by the Hysteresis. Generally, the hysteresis is set to 10 digits, however, it can be adjusted to values between 0 and 99 digits (s. 11.5.7). The exceeding of a limit value can also be used to start or stop a measurement (s. 11.4.3).

**Function:**

Enter limit value max (s. 9.5):

Limit value min:

Switching off the limit value:

Switching on the limit value:

7 Limit max: 123.4°C

7 Limit min: -----°C

<OFF>

<ON>

### 11.3.6 Scaling, Decimal Point Setting

For indicating the electrical signal of a sensor as a measured value of a physical variable it is, in most cases, necessary to set a zero point shift and to perform a multiplication with a certain factor. The functions BASE and FACTOR are available for this. A detailed description of the scaling, including an example, can be found in the manual section 6.3.11.

**Indicated value** = (Corrected Measured Value - BASE) x FACTOR.

The FACTOR can be programmed in the range from -2.0000 to +2.0000. For factors over 2.0 or under 0.2 a corresponding decimal point setting must be considered by entering the EXPONENT. The EXPONENT allows to shift the decimal point to the left (-) or right (+) as far as it can be indicated on the display and printer. An exponential presentation of the measured values is not possible.

For automatic calculation of the scaling values:

5 Base : -----

5 Factor: -----

5 Exponent: 0

In the ASSISTANT Menu there is an extra menu Scaling consisting of actual and set-point values.

The correction arrow ↗ will be indicated as status of the measured value (s. 9.3), if scaling values have been programmed and the actual measured value has been altered.

SCALING	
Connector: 0	Channel: 00
Actual value 1:	4.000 mA
Actual value 2:	20.000 mA
Decimal Places:	1
2 Dimension:	°C
SetPoint 1:	-100.0 °C
SetPoint 2:	400.0 °C
5 Base:	720.0 °C
5 Factor:	0.3125
5 Exponent:	2
4 SloPe correct:	-----
00:	27.0 °C
OK	F ESC



### 11.3.7 Correction Values

The correction values ZERO CORRECTION and SLOPE CORRECTION allow for correcting sensors with regard to zero point and slope (s. man. 6.3.10).

**Corrected Meas. Value** = (Meas.Value - ZERO CORR.) x SLOPE CORR.

#### Function:

Zero point correction:

**4 Zero correct:** -----°C

Slope correction:

**4 SloPe correct:** -----°C

Switch on/off keys:

**<OFF>** or **<ON>**

The correction arrow  will be indicated as status of the measured value (s. 9.3), if scaling values have been programmed and the actual measured value has been altered.

### 11.3.8 Changing the Dimension

Each measuring channel allows to replace the standard dimension of the measuring range by any other dimension that has two digits (see manual 6.3.5). In addition to all capital and normal letters, the characters Ω, %, [, ], \*, -, =, ~ and spaces ( ) are available. The dimension is indicated by two characters that are indicated next to the measuring and programming values.

The **dimension can be changed** using the function: **2 Dimension:** °C



When the dimension °F is entered a temperature value in degree Celsius will be converted into degrees Fahrenheit. The cold junction compensation can be switched off by using the characters !C. The following dimensions are automatically generated, entering 2 corresponding characters: ~~mls~~ at ~~ms~~, ~~m³lh~~ at ~~mh~~, ~~Wlm²~~ at ~~Wm~~, ~~gIk~~ at ~~gIk~~.

### 11.3.9 Selecting the Measuring Range

If users want to program the connectors on their own or if they frequently change the measuring range, it must be considered that the locking must be cleared, i.e. set to zero (s. 11.3.4), and that special connectors may be required for some transducers (e.g. thermo, shunt, divider etc., see table). To activate a new measuring channel, activate all channels by using the key **<MALL>** select the corresponding input channel (s. 11.3.1) and then enter the measuring range. With the input acknowledgement of the new measuring range all programming values of the input channel will be cleared.

Function Meas. Range Selection:

**1 RANGE:** NiCr

Enabling the selection of all avail. meas. channels:

**<MALL>**

Switch-off, i.e. deactivating a channel:

**<CLR>**

Switch-on, i.e. re-activating the channel:

**PROG** , **PROG**

Programming of range as with data input, 9.5

**PROG** ,  ... ,

**PROG**

## 11. Programming With Programming-Menus

In the input window all abbreviations of the following table are indicated successively

**1 RANGE:** **FECO**

and a corresponding help window to identify the sensors:

**ZA 9021FSL**  
**Thermocouple Typ L**  
**-200.0 ... 900.0 °C**

Transducer	Conn./Cable/ Sensor	Meas. Range	Dim	Display
<b>Pt100-1</b> ITS90	ZA 9000-FS	-200.0... +850.0	°C	P104
Pt100-2 ITS90	ZA 9000-FS	-200.00...+400.00	°C	P204
Pt1000-1 ITS90 (element flag 1)	ZA 9000-FS	-200.0... +850.0	°C	P104
Pt1000-2 ITS90 (element flag 1)	ZA 9000-FS	-200.00...+400.00	°C	P204
Ni100	ZA 9000-FS	-60.0... +240.0	°C	N104
<b>NiCr-Ni (K)</b> ITS90	ZA 9020-FS	-200.0...+1370.0	°C	<b>NiCr</b>
NiCr-Ni (K) ITS90 **	ZA 9020-SS2	-100.00...+500.00	°C	NiCr
NiCroSil-NiSil (N) ITS90	ZA 9020-FS	-200.0...+1300.0	°C	NiSi
Fe-CuNi (L)	ZA 9000-FS	-200.0... +900.0	°C	FeCo
Fe-CuNi (J) ITS90	ZA 9000-FS	-200.0...+1000.0	°C	IrCo
Cu-CuNi (U)	ZA 9000-FS	-200.0... +600.0	°C	CuCo
Cu-CuNi (T) ITS90	ZA 9000-FS	-200.0... +400.0	°C	CoCo
PtRh10-Pt (S) ITS90	ZA 9000-FS	0.0...+1760.0	°C	Pt10
PtRh13-Pt (R) ITS90	ZA 9000-FS	0.0...+1760.0	°C	Pt13
PtRh30-PtRh6 (B) ITS90	ZA 9000-FS	+400.0...+1800.0	°C	EL18
Au-FeCr	ZA 9000-FS	-270.0... +60.0	°C	AuFe
W5Re-W26Re (C) **	ZA 9000-SSC	0.0...+2320.0	°C	WR26
<b>Ntc Type N</b>	ZA 9000-FS	-30.00...+125.00	°C	<b>Ntc</b>
Ntc Typ N **	ZA 9040-SS3	0.000...+45.000	°C	Ntc3
Ptc Typ Kty84 **	ZA 9040-SS4	-0.0...+200.0	°C	KTY
<b>Millivolt 1</b>	<b>ZA 9000-FS</b>	<b>-26.000...+26.000</b>	<b>mV</b>	<b>mV 1</b>
Millivolt	ZA 9000-FS	-10.000...+55.000	mV	mV
Millivolt 2	ZA 9000-FS	-260.00...+260.00	mV	mV 2
Volt	ZA 9000-FS	-2.6000...+2.6000	V	Vol1t
Differential Millivolt 1	ZA 9000-FS	-26.000...+26.000	mV	D 26
Differential Millivolt	ZA 9000-FS	-10.000...+55.000	mV	D 55
Differential Millivolt 2	ZA 9000-FS	-260.00...+260.00	mV	D260
Differential Volt	ZA 9000-FS	-2.6000...+2.6000	V	D2.6
Sensor voltage	any	0.00...20.00	V	Batt
<b>Milliampere</b>	ZA 9601-FS	-32.000...+32.000	<b>mA</b>	<b>mA</b>
Percent (4-20mA)	ZA 9001-FS	0.00... 100.00	%	%
Ohm	ZA 9000-FS	0.00... 400.00	Ω	Ohm
Ohm **	ZA 9003-SS3	0.000... 50.000	Ω	Ohm1
Frequency	ZA 9909-AK	0... 25000	Hz	Freq
Pulse	ZA 9909-AK	0... 65000		Puls
Digital input	ZA 9000-EK2	0.0... 100.0	%	Inp

Transducer	Conn./Cable/ Sensor	Meas. Range	Dim	Display
Digital interface	ZA 9919-AKxx	-65000... +65000		DIGI
<b>Infrared 1</b>	ZA 9000-FS	0.0... +200.0	°C	Ir 1
Infrared 4	ZA 9000-FS	-30.0... +100.0	°C	Ir 4
Infrared 6	ZA 9000-FS	0.0... +500.0	°C	Ir 6
<b>Rotating Vanes Normal 20</b>	FV A915-S120	0.30... 20.00	m/s	S120
Rotating Vanes Normal 40	FV A915-S140	0.40... 40.00	m/s	S140
Rotating Vanes Micro 20	FV A915-S220	0.50... 20.00	m/s	S220
Rotating Vanes Mikro 40	FV A915-S240	0.60... 40.00	m/s	S240
Rotating Vanes Macro	FV A915-MA1	0.10... 20.00	m/s	L420
Rotating Vanes Water-Micro	FV A915-WM1	0.00... 5.00	m/s	L605
Dyn.press. 40m/s with TC u. PC	FD A612-M1	0.50... 40.00	m/s	L840
Dyn.press. 90 m/s with TC u. PC	FD A612-M6	1.00... 90.00	m/s	L890
Flow sensor SS20 **	ZA9602-SSS	0.50... 20.00	m/s	L920
<b>Rel. humidity cap.</b>	FH A646	0.0... 100.0	%H	% rH
Rel. humidity cap. with TC	FH A646-C	0.0... 100.0	%H	HcrH
Rel. humidity cap. with TC	FH A646-R	0.0... 100.0	%H	H rH
Humid temperature HT	FN A846	-30.00...+125.00	°C	P HT
<b>Conductivity probe with TC</b>	FY A641-LF	0.0 ...20.000	mS	LF
CO <sub>2</sub> Sensor	FY A600-CO2	0.0 ... 2.500	%	CO2
O <sub>2</sub> Saturation with TC a. PC	FY A640-O2	0 ... 260	%	O2-S
O <sub>2</sub> Concentration with TC	FY A640-O2	0 ... 40.0	mg/l	O2-C
<b>Function channels s. 11.3.10</b>				
* Mixture ratio with PC	FH A646	0.0 ... 500.0	g/kg	H AH
* Dew point temperature	FH A646	-25.0... 100.0	°C	H DT
* Partial vapour pressure	FH A646	0.0...1050.0	mbar	H VP
* Enthalpy with PC	FH A646	0.0 ... 400.0	kJ/kg	H En
* Rel. humidity psychr. with PC	FN A846	0.0 ... 100.0	%H	P RH
* Mixture ratio with PC	FN A846	0.0 ... 500.0	g/kg	P AH
* Dew point temperature with PC	FN A846	-25.0 ... +100.0	°C	P DT
* Partial vapour pressure with PC	FN A846	0.0 ... 1050.0	mbar	P VP
* Enthalpy with PC	FN A846	0.0 ... 400.0	kJ/kg	P En
Measuring value (Mb1)	any		f(Mb1)	Mess
Difference (Mb1-Mb2)	any		f(Mb1)	Diff
Maximum value (Mb1)	any		f(Mb1)	Max
Minimum value (Mb1)	any		f(Mb1)	Min
Average value over time (Mb1)	any		f(Mb1)	M(t)
Count of avg. values (Mb1)	any		f(Mb1)	n(t)
Avg.val. over meas.pts (Mb2..Mb1)	any		f(Mb1)	M(n)
Sum over meas. pts (Mb2..Mb1)	any		f(Mb1)	S(n)
Total pulse count (Mb1)	ZA 9909-AK2	0... 65000		S(t)
Pulse count/print cycle (Mb1)	ZA 9909-AK2	0... 65000		S(P)
Alarm value (Mb1)	any		%	Alrm

## 11. Programming With Programming-Menus

Transducer	Conn./Cable/ Sensor	Meas. Range	Dim	Display
Thermal coeff. $\bar{q}/(M01-M00)$	ZA 9000-FS		W/m <sup>2</sup> K	q/dT
Wet bulb globe temperature	ZA 9000-FS		°C	WBGT
Cold junction temperature	any		°C	CJ
Volume m <sup>3</sup> /h $\bar{M}b1 \cdot Q$	any		m <sup>3</sup> /h	Flow
Timer	any	s.10.4.6 0...65000	s	Time
Temp. for Refrigerant R22 °	FDA602Lx	-90.0...+79.0	°C	R22
Temp. for Refrigerant R23 °	FDA602Lx	-100.0...+26.0	°C	R23
Temp. for Refrigerant R134a °	FDA602Lx	-75.0...+101.0	°C	R134
Temp. for Refrigerant R404a °	FDA602Lx	-60.0...+65.0	°C	R404
Temp. for Refrigerant R407c °	FDA602Lx	-50.0...+86.0	°C	R407
Temp. for Refrigerant R410 °	FDA602Lx	-70.0...+70.0	°C	R410
Temp. for Refrigerant R417a °	FDA602Lx	-50.0...+70.0	°C	R417
Temp. for Refrigerant R507 °	FDA602Lx	-70.0...+70.0	°C	R507

TC = Temp. Compensation, PC = Atmospheric Pressure Compensation, Mbx = Reference channels

\* Calculated variables of humidity (Mb1=Temperature, Mb2=Humidity/Humid temp.)

++ only via special connectors with internal characteristic, others available by request) (see 10.3.11)

° 8 measuring ranges for refrigerants - only with device option R (Mb1 = pressure in mbar)

### 11.3.10 Function Channels

At the end of the table of measuring ranges and units (see above) under the sub-heading **Function channels** there is a group for representing function parameters in measured value processing or calculated results from linking certain measured values on measuring channels (see Manual 6.3.4). Reference to the actual measuring channels is provided by one or two reference channels. For all function channels the default reference channels Mb1 and Mb2 are available on the appropriate connector; these do not need programming.

Function	Function channel	Ref. Channel 1	Ref. Channel 2
* Humidity variables cap.	to 3. or 4.Channel	Mb1=Temperatur	Mb2=Humidity
* Humidity variables psy.	to 3. or 4.Channel	Mb1=TT	Mb2=HT
Function parameters (Mb1)	to 2., 3. or 4.Channel	Mb1= 1.Channel	
Difference (Mb1-Mb2)	to 2., 3., 4.Chan. (Mb1)	Mb1= 1.Channel	Mb2=M00
Avg. value over Mb2..Mb1	to 2., 3., 4.Chan. (Mb1)	Mb1= 1.Channel	Mb2=M00
Sum over Mb2..Mb1	to 2., 3., 4.Chan. (Mb1)	Mb1= 1.Channel	Mb2=M00
$\bar{q}/(M01-M00)$	to 2., 3., 4.Chan. (q)	Mb1= 1.Channel	Mb2=M05
WBGT	to 2.Channel (GT)	Mb1= 1.Channel	Mb2=M00

Arrangement of channels on the connectors :

Once the range has been programmed the standard reference channels can be used (see above). Settings for the reference channels are described in 11.4.6. The best approach is to use the **Function channel** assistant.

**A new feature is the presence of four device-internal channels:**

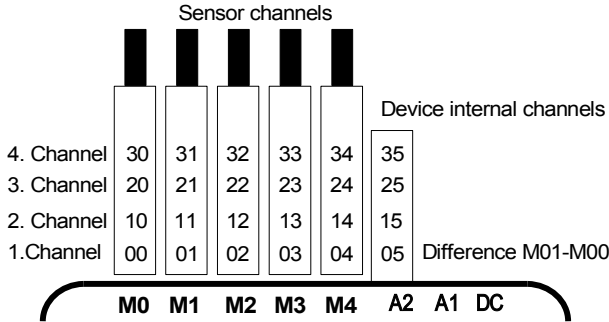

M5 is programmed by default as differential channel M1-M0; this applies if there are two sensors with the same units and same decimal point position connected at measuring points M0 and M1. However, all four channels can be used in conjunction with any function channels with standard reference channels Mb1=M1 and Mb2=M0 assigned; i.e. if you want to program a function parameter without reference channel on a device-internal basis, the sensor must be connected to M1.

#### **Advantage of device-internal channels:**

If several sensors are being used for the same application, they do not have to be reprogrammed and can be freely exchanged without losing their function channel assignment. However, if the whole application operates with just one sensor, then programming on the sensor itself makes more sense.

### **11.3.11 Special meas. ranges, linearization, multi-point calibration**

Thanks to the new ALMEMO special connectors with extra memory for additional data (larger EEPROM, code E4) the following tasks can now for the first time be elegantly performed :

1. Provision of special measuring ranges with internal characteristic (s. 10.3.9)
2. Linearization of signals for voltage, current, resistance, or frequency set by the user
3. Multi-point calibration of all sensors

The ALMEMO 2890-9 can as standard evaluate all appropriately programmed connectors. With the special KL variant it is also possible to convert measuring signals into appropriate display values in line with a characteristic of up to 30 support values. These support points are programmed to the EEPROM in the ALMEMO connector using the AMR-Control software. During a measuring operation the measured values are interpolated between these on a linear basis. When correcting non-linear sensors (e.g. with Pt100 or thermocouple sensors) initially the original characteristics are considered; then only the deviations are interpolated on a linear basis and inserted.

If a channel with a characteristic is deactivated or programmed with a different range, the characteristic is subsequently reactivated by programming the special range 'Lin' by means of the keyboard or command 'B99'.

## 11.4 Special Functions

The data logger 2690-8 has a separate menu allowing access to all ALMEMO® special functions, which despite only rarely being required during routine operation, are very useful for some applications (see manual 6.10). These functions can (to a certain extent) be very complex and should only be used if their operation is completely understood.

* SPECIAL FUNCTIONS *	
Connector:	1 Channel: 11
Print cycle factor:	01
U-Sensor min:	12.0 U
7 Action max:	Start R1
7 Action min:	Ende R2
6 Analog-start:	0.0 °C
6 Analog-end:	300.0 °C
Output function:	MESS
1 Reference ch. 1:	(01)
1 MultiPlexer:	(B-A)
Element flags:	IR
Calibration offset:	-12345
Calibration faktor:	43210
<b>M PRINT ESC</b>	

### 11.4.1 Print Cycle Factor

For the adaptation of the data recording to the update speed of the individual measuring points it is possible to program a print cycle factor between 00 and 99 to output measuring points less often or not at all (see manual 6.10.6). Only disturbed measuring points, e.g. on exceeding of limit values will always be output. Generally, the print cycle factor of all measuring points is cleared or set to 01, i.e. all activated measuring points will be output at each cycle. If a different factor, e.g. 10 is programmed, the corresponding measuring point will only be put out once in ten times, however, if 00 is programmed it will not be output. The data recording also allows to suppress unnecessary measured values and, as a result, saves memory space.

Enter the print cycle factor (s. 9.5) in function:  
Clearing the print cycle factor with the key:

**Print cycle factor: 01**  
**<CLR>**

### 11.4.2 Minimum Sensor Supply Voltage

Similarly to all ALMEMO® devices, the sensor supply voltage is also monitored in the 2690-8. It is also displayed in the menu **Power supply** (s. 11.7). However, there are also sensors, which require for a correct operation a supply voltage, which requires a charged accumulator or a power supply unit. To avoid measuring errors, the sensor programming allows to individually program the required minimum sensor voltage for each transducer. In case of falling below this voltage the measured value is treated as sensor breakage (indication L flashes).

Entering the minimum sensor supply voltage:  
Switching off the voltage control with the key:

**U-Sensor Min: 12.0 U**  
**<CLR>**  
**U-Sensor Min: ---- U**

## 11.4.3 Limit Value Responses

### Relay Allocation

As standard, both limit values of all measuring points of a device are used for fault alarms (s. 11.3.5), i.e. if an exceeding of a limit value occurs at any measuring point, the relay 0 responds if an Alarm Relay Cable or a corresponding Relay Adapter (s. man. 5.2/3) is used. It only opens again, after all measured values have dropped below the limit values by as much as the hysteresis. If a limit value has not been defined, the measuring range limit will be used as limit value. A sensor breakage will always cause a fault alarm.

To distinguish between max value exceeding and min value undershooting the alarm signal generators can be re-programmed to variant 1 (s. 11.6.2, 6.10.9).

If it is necessary to selectively identify and evaluate faults, the function **Action Max**, **Action Min** or the assistant menu **LIMITS, ALARM** can be used to allocate individual relays to the limit values. It is also possible to allocate several limit values to one relay. For this purpose the relay cables provide 2 relays (0 and 1) and the relay adapter (ZA 8000-RTA) provides 4 relays (0 to 3). This mode also has to be set as variant 2 in the output module (s. 11.6.2, man. 6.10.9).

```

LIMITS, ALARM
-----
Select measuring channel:
MO: 216.7 °C
7 Limit max:      300.0 °C
Relay: 0
7 Limit min:      100.0 °C
Relay: 1

Output socket: A2
Use alarm cable, set variant
EA Trigger-Alarm
2: Rx int. assigned
Relay: 01-----
M PRINT ESC
  
```

### Output socket: A2

Setting the relay module to variant 2:  
(relay int. allocated)

Activating relay x at limit value exceeding Max:

Activating relay y at limit value undershooting Min:

Clearing the relay allocation using the key:

EA Trigger-Alarm

2: Rx int. allocated

7 Action max: ----- **Rx**

7 Action min: ----- **Ry**

**<CLR>**

### Starting and Stopping a Measurement

Exceeding of limit values can not only be used for fault alarms but also to start or stop a measurement (s. man. 6.6.3). The start command or stop command is assigned to a limit value - also by means of the functions **Action max** and **Action min**.

Starting the measurement at exceeding of limit max:

Stopping measurement at undershooting of limit min:

manually scanning at exceeding of limit max:

Zero-setting timer 2 at limit value, maximum:

Execute macro 5 to 9 at maximum limit value:

Clear response by using the key:

7 Action max: **Start** -- S

7 Action min: **Stop** -- E

7 Action max: **Stop** -- M

7 Aktion max: **TZero** -- T

7 Aktion max: **Max 5** -- 5

**<CLR>**

Printout of relay assignment x (s. man 6.10.8) and action Y (s. man 6.6.3) as assembled code in the sensor programming (s. man 6.10.1).

### 11.4.4 Analog Output Start and End

In most cases the analog output of measured values to the analog output modules (see manual 5) or the display as bar or line chart must be scaled to a specified sub-range. For this, it is just necessary to specify the start and end value of the display range required by you. This range is then mapped to the analog range 2V, 10V, 20mA or, for the display, to 100 dots.

Programming the **analog output start**:                    **6 Analog start: 0.0°C**  
 Programming the **analog output end**:                    **6 Analog end: 100.0°C**

These two parameters, analog output start and analog output end, are also stored in the EEPROM of the sensor and can, therefore, be individually programmed for each channel, i.e. during a manual switch through the channels an individual scaling is available for each measuring variable.

The flag for switching over from 0-20mA to 4-20mA can be programmed through the element flags (s. 11.4.8).

There is the assistant menu **Analog output** (s. 11.6.3) to programm all parameters of an analog output.

### 11.4.5 Output Function

If not the real measured value but only the Max, Min, Average or Alarm value is required, then this function can be programmed as output function (see manual 6.10.4). As a result, only the corresponding function value will be considered for storing and analog or digital output. For control of the changed output function the symbol below is displayed next to the measured value (s. 9.3).

#### **Examples:**

1. If meas. values are averaged over the cycle only the average value is relevant as output value, but not the last measured value. This way, memory space can be saved in a data logger.
2. The analog measured value of the dew sensor FH A946-1 has no meaning. If the limit value Max is set to approximately 0.5V, and the measuring function 'Alarm Value' is programmed only the relevant values 0.0% for dry and 100.0% for 'dew' will be displayed.

<b>Output Function</b>	<b>Control Symbol</b>	<b>Menu</b>
Measuring value		<b>OutPut Function: Meas</b>
Difference	<b>D</b>	<b>OutPut Function: Diff</b>
Maximum value	<b>H</b>	<b>OutPut Function: Max</b>
Minimum value	<b>L</b>	<b>OutPut Function: Min</b>
Average value	<b>M</b>	<b>OutPut Function: M(t)</b>
Alarm value	<b>A</b>	<b>OutPut Function: Alrm</b>



### 11.4.6 Reference Channel 1

The arithmetic functions of the function channels, generally, refer to a particular measuring channel (or 2 meas. channels) (s. 11.3.10, man. 6.3.4). During the programming of a function channel the first channel of the corresponding sensor connector Mxx1 is automatically set as reference channel Mb1. The 2nd reference channel Mb2 (for difference, average value M(n) etc.) is, initially, the measuring point M00. In function **Reference ch. 1** it is possible to set other measuring points as reference channel, either absolutely by specifying a particular measuring point or by specifying the 'distance' referred to the function channel (e.g. -01 identifies the channel preceding the function channel).

Programming of the ref. channel 1 absolute:      **1 RefChannel 1:      01**  
 Programming of the ref. channel 1 relative:      **1 RefChannel 1:      -10**

### 11.4.7 Reference Channel 2 or Multiplexer

In case of function channels, which require a second reference channel (s. above), the function **Reference channel 2** will automatically be displayed in the line after **Reference channel 1**. In all other cases it is possible to change the pin assignment in the connector by changing the input multiplexer with the function **Multiplexer** (s. manual 6.10.2).

Programming of the ref. channel 2 absolute:      **1 RefChannel 2:      00**  
 Programming of the ref. channel 2 relative:      **1 RefChannel 2:      -01**  
 Measuring inputs B+ and A-, GND-referred      **1 Multiplexer:      B-A**  
 Measuring inputs C+ and A-, GND-referred      **1 Multiplexer:      C-A**  
 Measuring inputs D+ and A-, GND-referred      **1 Multiplexer:      D-A**  
 Differential measuring inputs C+ and B-          **1 Multiplexer:      C-B**  
 Differential measuring inputs D+ and B-          **1 Multiplexer:      D-B**

### 11.4.8 Element Flags

For a realization of sensor-specific additional functions, element flags can be activated at each measuring channel (s. manual 6.10.3)

Measuring current 1/10 for Pt1000, 5000Ω:      **ElementFlags:    I 1/10**  
 Emission and background temp. for IR sensors: **ElementFlags:    IR**  
 Meas. bridge with switch for final value simulation: **ElementFlags:    Bridge**  
 Digital channel, cyclic evaluation only          **ElementFlags:    Cyclic**  
 (Activation of all averaging functions:)\*       **ElementFlags:    Avg On**  
 (Element flag 6:)\*                                **ElementFlags:    Flag 6**  
 Switch-off of the sensor breakage detection:   **ElementFlags:    Br Off**  
 Analog output 4-20mA instead of 0-20mA:      **ElementFlags:    A 4-20**

\* At the ALMEMO 2690-8 these element flags have no meaning

## 11.5 Device Configuration

Some fundamental settings can be taken in the menu **DEVICE CONFIGURATION**. The device designation serves as print header in log printouts and facilitates the assignment within a network. Furthermore, the device address is imperative in a network. The baud rate can be adapted to external devices. Three levels are available for the lighting of the display. The setting of the atmospheric pressure for the compensation of certain sensors is particularly suitable at corresponding altitudes. The standard value of the hysteresis of alarm relays can be changed. For checking the device the channel number and cold junction temperature are indicated.

```

* DEVICE CONFIGURATION *
Device designation:
Ahlborn, Holzkirchen
Device: 00          U: 6.05 XY
Baud rate:         9600 Bd
Language:          Deutsch
Lighting level:    1
Lighting duration: 20 s
Contrast:          50 %
Air. Pressure:     1013 mb
Hysteresis:        10
Configuration: FCR-----
Meas.channels: 40 Active: 05
CJ-Temperature:   25.4 °C
PRINT ESC
  
```

### 11.5.1 Device Designation

The function **Device designation** (s. manual 6.2.4) allows to enter any text with max 40 digits (s. 9.5). The text appears in the main menu, in the print header of a measurement and in device lists (software).

Function **Device designation:**

**Device designation:**  
Ahlborn, Holzkirchen

### 11.5.2 Device Address and Networking

All ALMEMO® instruments can be very easily networked to centrally acquire the measured values of several instruments that are located at different places (see manual 5.3). For communicating with networked devices it is mandatory that all devices have the same baud rate and an own individual address as only one device is allowed to respond to each command. Therefore, before any network operation it is necessary that all connected devices are set to different device numbers. For this, the function **Device** is available. Generally, the device number 00 is set as the factory default value in this function. It can be changed by the usual data entry (s. 9.5). For checking purposes it is followed by the device type, the version number and, possibly, an option code (s. manual 6.10.11).

Device address with type, version, option: **Device: 00 2690-8 U:6.05XY**

*Example:* address: 00, type: 2690-8, version: 6.05, option: XY



Only successive numbers between 01 and 99 should be entered for network operation so that the device 00 cannot be falsely addressed in case of a power supply failure.

### 11.5.3 Baud Rate, Data Format

All interface modules are factory-set and programmed to 9600 baud. To avoid unnecessary problems when networking several devices the baud rate should not be modified but the computer or printer should be set up accordingly. If this is not possible the values 1200, 2400, 4800, 9600bd or 57.6, 115.2 kbd can be entered in the function **Baud Rate** (please consider the max. baud rate of the interface module!). The baud rate setting will be stored in the EEPROM of the interface module and will then be valid for use with all other ALMEMO devices.

Function **Baud Rate** : **BaudRate: 9600bd**

**Data Format:** unchangeable 8 data bits, no parity, 1 stop bit

### 11.5.4 Language

The language of the function legend and the printouts can be set to German, French or English. The soft keys are international code and are not meant to be altered:

Language selection in function **Language** s. 9.5: **Language: English**

### 11.5.5 Lighting and Contrast

The background lighting of the display can be switched on or off in 3 levels in the selection menus by using the key **< \* ON >** or in the function **Lighting** of the device configuration (attention, the power consumption is five times higher in level 3!). If the lighting is switched on when a mains supply adapter is not connected, the lighting will switch off in a configurable lighting time after the last key was operated (pause), and it will switch on again as soon as any key is operated. With the function **Contrast** the contrast of the display can be set to 10 different positions.

Switching on the lighting, level 1 to 3:

**Lighting level: 2**

Switching off the lighting, level 0:

**Lighting level: 0**

Entering the lighting time from 20sec to 10 min:

**Lighting time: 20s**

If the **lighting is switched on**,

the status line provides the symbol:

\* Lighting on

If it is temporarily switched off, lights up:

\* Pause

Switch-on **without** function by using the key:

**<ESC>**

Setting the contrast (10 to 100%) s. 9.5:

**Contrast: 50%**

### 11.5.6 Atmospheric Pressure

For compensation of various sensors the atmospheric pressure can be entered (s. 10.2.6). If it is measured, it will also be indicated in this function:

Entering the atmospheric pressure in function: **Atm. Pressure 1013mb**

### 11.5.7 Hysteresis

In case of an exceeding of limit values the hysteresis of an alarm condition can, generally for all sensors, be set in the function **Hysteresis** (s. 11.3.5 and manual 6.2.7) within the range from 0 to 99 digits (standard setting is 10 digits).

Change hysteresis (0 to 99) s. 9.5: **Hysteresis: 10**

### 11.5.8 Operating Parameters

Some operating parameters are software options and can be user-configured with the function **Configuration** (s. manual 6.10.13.2).

Mains frequency noise suppression 60Hz instead of 50Hz	<b>Configuration: F-----</b>
Clearing all measured values on start of a measurement	<b>Configuration: -C-----</b>
Ring memory (overwriting of old data when full)	<b>Configuration: --R-----</b>
Immediate output via the interface, oversampling	<b>Configuration: ----A---</b>
Switching off the signal transmitter	<b>Configuration: -----S--</b>

The following parameters can be used to check the device function:

Out of 20 channels 5 are activated: **Meas.Chan:20 active:05**

Cold junction temperature = socket temperature: **CJ-TemPerature: 25.4°C**

### 11.6 Output Modules

The data logger ALMEMO® 2690-8 has two output sockets, A1 and A2, to allow an output of the measured values as analog or digital values or as alarm signals. Furthermore, it is possible to trigger various functions through trigger pulses. To suit all possibilities, while keeping the hardware requirements at a minimum, all necessary interfaces have been integrated into the ALMEMO® output connectors or modules.

The output modules, like the sensors, are automatically detected and displayed in the menu **OUTPUT MODULES**.

With the relay trigger analog modules certain function variants can be configured (see 11.6.2 Fehler: Referenz nicht gefunden), relays can have certain limit values assigned to them (see Fehler: Referenz nicht gefunden), or analog outputs can be assigned to certain measuring channels. In this menu all ports can be selected and configured accordingly. The connection possibilities are described in the instructions for the output module concerned.

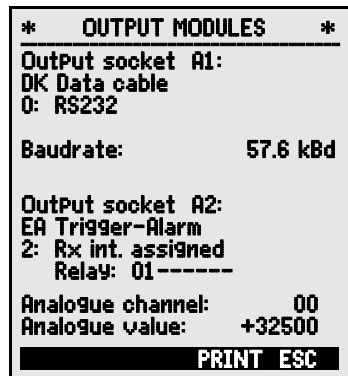

### 11.6.1 Data cable

The serial interface can be used to output cyclic data logs, all function values of the measuring menus, as well as the whole programming of the sensors and the device to a printer or computer. The ALMEMO® data cables and the connection to the instruments are described in the manual section 5.2. Other modules for networking the instruments follow in the manual section 5.3.

All available interface modules are connected to the socket A1 (2), exception: network cables ZA1999-NK to network a further instrum. are connected to A2.

Under the prevailing socket the menu indicates:

```

Outout Socket A1:
DK Data cable
0: RS232
Baudrate: 9600 Bd

```

Variant 0: Standard interface always active

The baud rate is also stored in the cable connector:

### 11.6.2 Relais Trigger modules

Whereas, for the purposes of addressing peripheral devices via the relay and trigger input (see Manual 5.1.2/3), V5 modules (ZA 1000-EAK, ZA 8000-RTA) provide only one function variant (see Manual 6.6.4), the new V6 relay trigger analog adapter ZA 8006-RTA3 offers up to 10 relays or options with 2 of these as trigger inputs or up to 4 as analog outputs. All elements can be configured individually for these functional variants. Old output cables can be reconfigured for V6 functions by means of AMR-Control. These modules can be connected equally well to output socket A2 or output socket A1 (2). To ensure that all elements are addressed, each of these sockets has been assigned 10 port addresses.

```

*   OUTPUT MODULES   *
ZA 8006-RTA3   Socket: A2
Port: 0           Adr.: 20
Relais: normally oPen 0.5A
2: Relais driven externally
Zustand: activ oPen
Watchdog:  ✓ Error

```

ON OFF P PRINT ESC

#### Socket Connection

**A1** V6 output modules at socket A1  
**A2** V6 output modules at socket A2

#### Port addresses

10..19  
 20..29

In the "Output modules" menu the elements of the output modules can be individually selected and functions programmed as follows (see Manual 6.10.9):

First **select the port** by pressing :

<P>: ▲ or ▼

e.g. port 0, socket A2 (port address 20) :

Port: 20

The element concerned is recognized :

#### Relay :

Relay type = NO (normally open) :  
 Relay type = NC (normally closed) :  
 Relay type = changeover :

Relay : NO  
 Relay : NC  
 Relay : Changeover

The relay switching mode can be configured to the following variants; see 9.5:

- 0: Alarm if any one channel of all channels is faulty
- 2: Alarm for a programmable channel
- 3: Alarm, if one limit value - maximum of all is overshoot
- 4: Alarm, if one limit value - minimum of all is undershot
- 8: Relay driven via interface or keypad

- 0: Summated alarm
- 2: Assigned internally
- 3: Summated alarm - maximum
- 4: Summated alarm - minimum
- 8: Driven externally

Variant 2 "Assigned internally" also requires the assignment of relays to certain limit values; (see 11.4.3).

For the purposes of **detecting power failure** it is an advantage if relays are driven on an inverted basis because in the absence of current an alarm status applies automatically. The function variants are therefore also provided on an inverted basis.

**Inverted relay control** : e.g. variant 2 inverted : **-2: Assigned internally - Inverted**

The **activation mode** and **actual contact status** resulting from the relay type and driving mode are displayed in the next line.

**Activation mode and relay contact status** : **Status : active oPen**

**Relay variant 8 "Driven externally"** permits manual activation of the relays via the keypad or via the interface; (see Manual 6.10.10).

Relay variant 8 :

For manual activation of relays press :

**8: Driven externally**  
**<ON>** or **<OFF>**

The watchdog setting for the RTA then appears: see above.

## Trigger inputs

For the purpose of controlling the measuring sequence 2 trigger inputs are provided at ports 8 and 9 (keypad or optocoupler).

The trigger source "key" and / or "optocoupler" can be defined directly in the RTA3 by pressing keys **PROG**, **▲** / **▼**, **PROG** or the trigger function can, for safety reasons, be switched off altogether by means of "OFF".

```

*   OUTPUT MODULES   *
Socket: A2   ZA 8006 RTA3
Port:      8           Adr.:28
Trigger: key+oPtocouPler
0: Start-Stop

P PRINT ESC
    
```

## The following trigger functions

can be programmed as function variants :

- |   |                                 |
|---|---------------------------------|
| 0: Start and stop a measuring operation                         | 0: Start / stop                 |
| 1: Once-only manual measuring point scan                        | 1: Once-only scan               |
| 2: Clear all maximum / minimum values                           | 2: Delete max. / min. values    |
| 3: Print measured value   | 3: Print                        |
| 4: Start / stop a measuring operation on level-controlled basis | 4: Start/stop, level-controlled |
| 8: Set measured value to zero                                   | 8: Set measured value to zero   |
| -5: Execute macro 5 (see Manual 6.6.5)                          | -5: Makro5                      |
| -6: Execute macro 6   | -6: Makro6                      |
| -7: Execute macro 7   | -7: Makro7                      |
| -8: Execute macro 8   | -8: Makro8                      |
| -9: Execute macro 9   | -9: Makro9                      |

### 11.6.3 Analog Output

For an analog recording of measured values it is still possible, at sockets A1 and / or A2 (2) to connect V5 output modules with an analog output, e.g. via recording cable ZA1601-RK -1.2 to 2.0 V (see Manual 5.1.1) and to configure these in the "OutPut modules" menu.

The new V6 relay trigger analog adapter ZA8006-RTA3 offers, at ports 4 to 7, the option of up to 4 additional separately configurable analog outputs; (see 11.6.2), with the following possible output signals :

Voltage 0 to 10 V                      0.5 mV / digit  
Current 0 to 20 mA                      1 µA / digit

**Programming** is as for relay and trigger inputs :

**To select socket and port** press :

<P> : ▲ or ▼

**The following output modes** can be programmed as variants :

0: Measured value for the selected measuring channel : **0: Selected meas. chan. M00**  
2: Measured value for a programmed channel : **2: Assigned internally M01**  
8: Programmed analog output (see below) : **8: Driven externally**

The **analog value** appears below this with the units :

**Analog value : 12.456 mA**

The **meas. val. for the selected meas. channel** Mxx is output in variant 0. In this mode the semi-continuous measuring rate (see 11.1.3) is the most suitable because in this way the analog output will be processed most frequently.

#### Assigning an analog output to a measuring point

In variant 2 "Assigned internally", after selecting the Mxx function, you can program the measuring point to be output :

**2: Assigned internally M**

In this case the continuous measuring rate (see 11.1.3) is better.

#### Scaling the analog output

When configuring a measured value output it is also possible, in the same menu, by means of the functions "Analog start" and "Analog end", to have the measuring range actually used for the measuring point concerned spread over the full 10 V or 20 mA; (see 11.4.4).

**To program the analog output start :** **6 Analog start : 0.0 °C**  
**To program the analog output end (see 9.5) :** **6 Analog end : 100.0 °C**

For 20 mA analog outputs only

To choose between 0 - 20 mA and 4 - 20 mA output: **Current output: 4-20 mA**

#### Programmed analog value output (see Manual 6.10.7)

In variant 8 "Driven externally"

**8: Driven externally**

the analog output value can be programmed (see 9.5): **Analog value: 5.000 mA**

ANALOG OUTPUT	
Output socket:	A2
RK Recording cable	20mA
Select measuring channel:	00: 216.7 °C
Scaling:	
Analog-start:	0.0 °C
Analog-end:	300.0 °C
Current output:	4-20 mA
Analogue value:	15557
<b>M PRINT ESC</b>	

## 11.7 Menu Power Supply

Power for the measuring instrument is normally supplied from three AA battery cells, either standard or rechargeable. The **POWER SUPPLY** menu provides an estimation of the battery's remaining operating time in the form of a current voltage display. At 3.5 volts the battery symbol in the status line starts to flash and at 3.1 volts the device switches off automatically. The current charge status cannot be displayed more exactly than this because of the different types of battery cell available.

To power the sensors a selectable sensor voltage is generated (approx. 6, 9, or 12 volts). With sensors that draw a lot of current but manage with relatively low voltage, the ideal sensor voltage selection can save a lot of energy.

Setting the desired Sensor Voltage:

Display of actual sensor voltage:

If a mains adapter is connected, the sensor voltage will always be over 9V:

The max. admissible current is also displayed:

Our range of accessories includes a rechargeable battery set ZA2690-AS, comprising three NiMH 1.6-Ah accumulators and an intelligent charge adapter. These rechargeable batteries are coded in such a way that they can be recognized and correctly recharged in the device. They can be charged up quickly and easily irrespective of their current charge status at any time. The charge adapter regulates the charging current according to the maximum admissible current of the mains adapter and the capacity of the rechargeable batteries in such a way that the recharging process can be completed as quickly as possible. However, in normal operating conditions the current is reduced in order to reserve sufficient current for the measuring instrument and sensors and to avoid adversely affecting measuring quality.

With mains adapter ZB 1312-NA7 the process of charging by device switched off takes 2 hours and for device in operating 4 hours, higher capacities accordingly longer.

For the duration of the charging phase the green LED on the adapter remains lit continuously; as soon as the battery is fully charged, the adapter switches over to trickle charge and the LED starts flashing.

If the accumulators are discerned (contact),

there appears in the display:

The accumulator capacity must be programmed:

In charging mode the charge status is displayed:

* POWER SUPPLY *	
Battery voltage:	3.8 V
Sensor voltage set:	9.0 V
Sensor voltage act:	8.6 V
Mains adapter:	12.0 V
Maximum current:	1.0 A
Accus:	✓
CaPacity:	1600mAh
Charge mode:	Charge
Charge current:	1.7 A
PRINT ESC	

Sensor voltage set: 9.0 V

Sensor voltage act: 9.1 V

Mains adapter: 9.3 V

Maximum current: 1.0 A

Accumulators: ✓

CaPacity: 1600mAh

Charge mode: Charge



The charging current is set automatically:  
 As soon as the accumulator is fully charged,  
 charging status displays:  
 the charge current switches over to trickle charge:  
 If the battery temperature is either too high or too  
 low for charging or if the mains adapter is too  
 weak etc., the charging mode displays, e.g.:  
 or a numbered error mistake:

**Charge current:** 1.60 A  
**Charge mode:** full  
**Charge current:** 0.01 A  
**Charge mode:** T too high  
**Charge mode:** Error 1

## 11.8 The locking and calibration menu (option KL)

In the **"Locking and calibration" menu** you can lock the right-of-access to certain menus and to certain functions. Here you can also see the serial numbers and calibration data for the device itself and for any sensors attached. With option KL it is possible not only to correct the sensor at several points in the connector itself but also to manage the associated calibration data.

The right-of-access to this and other menus and to certain key functions can be stipulated in detail and protected by password by means of the parameters "Menu" and "Fct".

```

* LOCKING-CALIBRATION *
Password:          ****
Locking level: Menu: 0 Fct: 0
Device:           2890-9 6.22
Serial number:    04020123
Next calibration: 01.12.05
Signal for calibration: ✓
Sensor:           Channel: 00
Type:            FHAG46-6
Serial number:    04020123
Next calibration: 01.02.06
Calibr. interval: 12 Month
PRINT ESC
  
```

### Menu Locking the menus

- 0 none
- 1 + calibration menu, except password
- 2 + programming menus, except recording to memory and output from memory
- 3 + recording to memory and output from memory
- 4 + wizard menus
- 5 + measuring menus, except user menu U1

### Fct Locking the functions

- 0 none
- 1 + data input, switching on and off
- 2 + clearing measured data
- 3 + start / stop / output measuring operation
- 4 + function selection, measuring point selection

### and keys

**PROG, ON, OFF, ZERO, ADJ**  
**CMEM, CLR, CLRA**  
**START/STOP, MANU, ARRAY, PRINT**  
**PROG, F▲, M▲**

No password, locking with new password:

**Password :** - - - -

Locked with password, enter correct password

**Password :** \*\*\*\*

Select locking level, menu, and function :

**Locking mode : Menu: 0 Fct: 0**

The device type (with version and serial number) and the sensors (with order number and serial number) are displayed. With option KL you can enter the date of the next calibration and the calibration interval in months. If "Calibration message" is activated then, as soon as the next calibration is due, a message to this effect will appear when the device is switched on.

## 12. TROUBLESHOOTING

The data logger ALMEMO 2690-8 can be configured and programmed in many different ways. It allows for a connection of many different sensors, additional measuring instruments, alarm signalisers and peripheral devices. Due to the large variety of options it is possible that, under certain conditions, it does not perform as the user would expect. In most cases this will not be related to a defective device but to operating errors such as wrong settings or an inadmissible wiring. The following tests should be performed to correct or to correctly identify the error.

**Error:** No display at all or faulty display, no key response

**Remedy:** Check power supply, recharge battery, switch off and on again, re-initialise, if required (see point 7.6 Fehler: Referenz nicht gefunden)

**Error:** Incorrect measured values

**Remedy:** Thoroughly check the entire programming of the channel, particularly base and zero point (menu 'Sensor Programming' and 'Special Functions')

**Error:** Varying meas. values or blockage during operation

**Remedy:** Check cabling for inadmissible electrical connection, disconnect all suspicious sensors, connect hand-held sensors and operate them in air or connect dummies (short circuit AB at thermocouples, 100  $\Omega$  at Pt100 sensors) and check, then reconnect sensors successively and check.

If an error occurs with one sensor, check the wiring, isolate the sensor if necessary, prevent influences from disturbances by shielding or twisting.

**Error:** Data transmission via interface does not function

**Remedy:** Check interface module, connections and setting: Are both devices set to the same baud rate and transmission mode (s. 11.5.3)?  
Is the correct COM interface addressed at the computer?  
Is a printer in ONLINE mode?  
Are the handshake lines DTR and DSR active?

A small interface tester with LEDs is very useful for checking the data flow and the handshake lines (during standby mode the data lines TXD and RXD are on a negative potential of approximately -9V and the LEDs are illuminated green. The handshake lines DSR, DTR, RTS and CTS have a positive voltage of approximately +9V and the LEDs are illuminated red. During the data transmission the data LEDs must flash red).

Test the data transmission by using a terminal (AMR-Control, WIN-Control, WINDOWS Terminal):

Select output channel interface U by using the command 'A1',  
Address the device with its device number 'Gxy' (s. man. 6.2.1),  
if the computer is in XOFF state, enter <Strg Q> for XON,  
query the programming through 'P15' (s. man. 6.2.3),

Only check the sending line by cycle input via command 'Z123456' and control in the display

Test the receiving line with the key <PRINT> and by monitor control.

**Error:** Data transmission within the network does not function.

**Remedy:** Check that all devices are set to different addresses, address all devices in-

dividually via terminal and command 'Gxy'.

Addressed device is OK when the feedback is at least 'y CR LF'.

If data transmission is still not possible, disconnect networked devices, check all devices separately using the data cable of the computer (see above),

check the wiring regarding short circuit or twisting.

Are all network distributors supplied with power?

Net-

work and check the devices successively again (see above).

If the device is, after the above inspections, still not performing as specified in the operating instructions, it must be sent to the factory in Holzkirchen, Germany, including a short report and, possibly, control printouts. Additionally, the software AMR-Control allows to print the monitor pages including the programming and also to save an extensive 'function test' in the device list or the terminal operation and to print it out.

### 13. DECLARATION OF CONFORMITY

Ahlborn Mess- und Regelungstechnik GmbH declares herewith that measuring instrument ALMEMO® 2590 carries the CE label and complies in full with the requirements of EU directives relating to low voltage and to electromagnetic compatibility (EMC) (89/336/EWG).

The following standards have been applied in evaluating the product.

IEC 61326:1997+A1:1998+A2:2000

IEC 61000-6-3:1996

IEC 61000-6-1:1997

IEC 61000-4-2: 1995+A1:1998+A2:2000 8kV

IEC 61000-4-4: 1995+A1:2000 2kV

IEC 61000-4-3: 1995+A1:1998+A2:2000 3V/m

IEC 61000-4-5: 1995+A1:2000

IEC 61000-4-6: 1996+A1:2000

IEC 61000-4-11: 1994+A1:2000

If a product is modified in any manner not agreed with us in advance, this declaration becomes void.

When using the sensor with an extension care must be taken to ensure that wiring is not laid alongside or close to high-voltage power cables and that it is, if necessary, properly shielded so as to prevent spurious interference being induced in the system.

The following advisory notes must be observed when operating the device :

Using the device in strong electromagnetic fields may aggravate measuring errors (<50 µV at 3 V/m and 1.5 meters thermocouple sensor). After exposure to such irradiation ceases, the device will again operate within its technical specifications.

## 14. APPENDIX

### 14.1 Technical Data

(see manual 2.3)

#### Measuring inputs:

Meas. channels:

5 ALMEMO® sockets for ALMEMO® flat connectors  
5 primary channels el. isol., max. 19 add. channels  
for double sensors and function channels

AD-converter:

Sensor voltage supply:

Delta-sigma >16bit, 2.5, 10, 50, 100 M/s, amplific. 1..100  
6V 0.2A, 9V 0.15A, 12V 0.1A (mains adapter: 12V)

#### Outputs:

2 ALMEMO® sockets for all output modules

#### Equipment:

Display:

graphics 128x128 dots, 16 lines à 4mm

Operation:

9 keys (4 softkeys)

Memory:

512kB EEPROM (approx. 100000 Meas.values)

Time and Date:

real time clock buffered with Lithium battery

Microprocessor:

M16C62P

#### Power supply:

ext. 6...13V DC

Batteries:

3 Alkaline Mignon type AA or

3 Accumulators NiMH-Mignon type AA 1.6 Ah

Mains adapter standard:

ZA 1312-NA7 230V AC to 12V DC, 1.0 A

Adapter cable electr. isolated:

ZA 2690-UK 10...30V DC to 12V DC, 0.25 A

Current consumption without  
input and output modules:

active mode: approx. 30 mA

with lighting: approx. 50..150 mA

sleep mode: approx. 0.05 mA

#### Housing:

L204 x B109 x H44 mm, ABS, weight: 550g

#### Operation conditions:

Operating temperature:

-10 ... +50 °C (storage temperature: -20 ... +60 °C)

Humidity of ambient air:

10 ... 90 % rH (non-condensing)

## 14.2 Product overview

### Data logger ALMEMO 2690-8

5 inputs, max. 24 channels, 2 outputs, cascadable interface,

9 keys, LCD graphics display, real time clock, 512kB EEPROM memory MA 2690-8

#### Options

Measuring rate to 400 mops only possible for 1 measuring point SA0000-Q4

Measuring ranges for temperature display of 8 refrigerants SB 0000-R

Linearization or multi-point calibration of sensors,  
calibration data management, OA 2690-KL

#### Accessories

Memory connector including SD card, minimum 128 MB (RS) ZA1904-SD

Mains adapter with ALMEMO connector 12V, 1.0 A ZA 1312-NA7

Accumulator set with 3 NiMH-Mignon cells 1600 mAh coded and

fast charging adapter for 3-9 NiCd- or NiMH cells, 12V, max. 2A ZA 2690-AS

DC Adapter cable 10 to 30V DC, 12V/0.25A electr. isolated ZA 2690-UK

ALMEMO® Recording cable -1,25 to 2,00 V ZA 1601-RK

ALMEMO® Data cable USB Interface, electr. isolated, max. 115.2kB ZA 1909-DKU

ALMEMO® Data cable V24 Interface, electr. isolated, max. 115.2kB ZA 1909-DK5

ALMEMO® Network cable, electr. isolated, max. 115.2kB ZA 1999-NK5

ALMEMO® I/O cable for triggering and limit value alarm ZA 1000-EGK

ALMEMO®-V6-Relay-Trigger-Analogadapter (4 Relays, 2 Triggerinputs) ZA8006-RTA3

## 15. Keyword index

accumulator capacity	11.7	72
Accumulator operation	7.2	16
Action max and Action min	11.4.3	63
activation mode	11.6.2	70
actual contact status	11.6.2	70
Additional Channels	8.2	18
Alarm Relay Cable	11.4.3	63
Analog Output	11.6.3	71
Analog Output Start and End	11.4.4	64
Assistant-Menus	10.6	20, 42
Atmospheric Pressure	11.5.6	67
Atmospheric Pressure Compensation	10.2.6	28
Averaging	10.4	33
Averaging Mode	11.3.3	34, 55
Averaging over Manual Single Measurements	10.4.3	34
Averaging over several Measuring Points	10.4.8	38
Averaging over the Cycle	10.4.7	37
Averaging over the Measuring Time	10.4.5	36
Bar chart	10.5.1	40
Base	11.3.6	56
Battery operation	7.1	16
Baud Rate	11.5.3	67
Changing the Dimension	11.3.8	57
Charge mode	11.7	72
CJ-Temperature	11.5.8	68
Clear memory	11.2.6	54
Cold Junction Compensation	10.2.7	29
Cold junction temperature	11.5.8	29, 68
Comment	11.3.2	55
Compensation	10.2	25
Configuration	11.5.8	68
Configuration of the menus	10.7.2	44
Connection of the Transducers	8	18
Continuous Measuring Point Scan	11.1.3	47
Contrast	11.5.5	67
Control Symbols	9.3	21
Conversion Rate	11.1.3	47
Correction of the Meas. Value	10.2	25
Correction Values	11.3.7	57
Current output:	11.6.3	71
Cycles	11.1	46
Cyclic Output	10.3.2	30
Damping of Meas. values	10.4.1	34

Data Acquisition	11.2.2	50
Data buffering	7.7	17
Data cable	11.6.1	69
Data Entry	9.5	22
Data Format	11.5.3	67
Data Memory	11.2	49
Decimal Point Setting	11.3.6	56
Declaration of conformity	13	75
Device Address	11.5.2	66
Device Configuration	11.5	66
Device Designation	11.5.1	66
Differential Measurement	10.5.2	40
Display	9	20
Display of Several Measuring Points	10.5	40
Element Flags	11.4.8	65
Equipment	14.1	76
Exponent	11.3.6	56
Extent of the Delivery	3.2	7
External DC Voltage Supply	7.4	17
Factor	11.3.6	56
Function Channels	11.3.10	60
Function Keys	9.2	21
Function Printouts	10.7.3	45
Function Selection	9.4	22
Functions	5.1	10
Guaranteed	3.1	6
Housing	14.1	76
Hysteresis	11.5.7	56, 68
Initial Operation	6	15
Inverted relay control	11.6.2	70
Isolation	8.3	19
Keypad	9	20
Language	11.5.4	67
Level of damping	10.4.1	34
Lighting	11.5.5	20, 67
Limit Value Responses	11.4.3	63
Limit Values	11.3.5	56
Line Diagram	10.3.5	32
Locking the Programming of the Sensor	11.3.4	55
Mains Operation	7.3	17
Max Time	10.1.2	24
Maximum current	11.7	72
Meas. points list	10	23
Measurement	5.1.2	12
Measurement Time	10.4.6	36

Measuring	10	23
Measuring duration	10.4.6	36
Measuring inputs	14.1	18, 76
Measuring Point Designation	11.3.2	55
Measuring point scans	10.3	30
Measuring with one Measuring Point	10.1	24
Measuring-Menus	10	20, 23
Memory Output	11.2.6	31, 53
Memory space	10.3.3	31
Menu List of Measuring Points	10.5.3	41
Menu Power Supply	11.7	72
Menu Selection	9.1	20
Min Time	10.1.2	24
Minimum Sensor Supply Voltage	11.4.2	62
Multi Channel Display	10.5.1	40
Multiplexer	11.4.7	65
Net Measurement	10.4.4	35
Networking	11.5.2	66
Numbering of measurements	11.2.3	51
Operating Controls	1	2
Operating Parameter	11.5.8	68
Operation conditions	14.1	76
Order No.	14.2	77
output cables	11.6.2	69
Output Format	11.1.2	30, 46
Output Function	11.4.5	64
Output Modules	11.6	68
Output of Menu Functions	10.3.4	31
P-OFF	9.1	20
Peak Value Memory	10.1.2	24
Power supply	14.1	16, 76
Print Cycle Factor	11.4.1	62
Process flow control	5.1.3	13
Product overview	14.2	77
Programmed analog value output	11.6.3	71
Programming-Menus	11	20, 46
Reference Channel 1	11.4.6	65
Reference Channel 2	11.4.7	65
Reinitialisation	7.6	17
Relais Trigger modules	11.6.2	69
Relay Adapter	11.4.3	63
Relay Allocation	11.4.3	63
Relay-Trigger-Analogadapter	14.2	77
Safety instructions	4	8
Scaling	11.3.6	56



Scaling the analog output	11.6.3	71
Scanning mode	11.2.5	51
Selecting the Input Channel	11.3.1	54
Selecting the Measuring Point	10.1.1	24
Selecting the Measuring Range	11.3.9	57
Sensor Adjustment	10.2.3	26
Sensor Programming	11.3	10, 54
Sensor Supply	7.5	17
Sensor Voltage	11.7	72
Setpoint Entry	10.2.4	27
Setting the Meas. Value to Zero	10.2.1	25
Single Output	10.3.1	30
Sliding averag. window	10.4.1	34
Slope correction	11.3.7	57
Special Functions	11.4	62
Special Meas. Operations	10.6	42
Standard display	10.1	24
Starting and Stopping of measurements	11.2.4	51
Storage Activation	11.1.2	46
Supply Voltage Control	7.1	16
Switch off	9.1	20
Switch On/Off	7.6	17
Technical Data	14.1	76
Temperature Compensation	10.2.5	28
Thermal Coefficient	10.6.1	42
Time and Date	11.1.1	46
Time and Date of End	11.1.4	48
Time and Date of Maximum Value	10.1.2	24
Time and Date of Start	11.1.4	48
Timer	10.4.6	37
Transducers	8.1	18
Trigger inputs	11.6.2	70
Trigger modules	11.6.2	69
Troubleshooting	12	74
Two-point Adjustment	10.2.4	27
U-Sensor Min	11.4.2	62
User Menus	10.7	43
Volume Flow Measurement	10.4.9	39
Waste disposal	3.3	7
Wet Bulb Globe Temperature	10.6.2	42
Zero Point Adjustment	10.2.2	26
Zero point correction	11.3.7	57

## 15.1 Your contact



