

INSTRUCTION MANUAL

MOVISTROB® Series 3000

Type MINISTROB 3000 N/A; 3000 B/A



Image:
Type 3000 N/A
Art.No.: 3110 / 3111

3000 N/A, ▶ Art.No.: 3110 – Art.No.: 3111 ▶ (230V AC or 115V AC)
3000 B/A, ▶ Art.No.: 3118 (12 V DC)

BBE Bamberg + Bormann - Electronic GmbH
Wiebelsheidestraße 45
D-59757 Arnsberg / Neheim-Hüsten
Tel.: 0049 (0)2932-547760
Fax: 0049 (0)2932-34675
Internet: <http://www.bbe-electronic.de>
e-mail: info@bbe-electronic.de

Legend: **N = AC Power** **B = DC Power (Battery operated)** **A = Analogue**

1. Introduction

Each MOVISTROB® product has to pass through various controls during its production phases and must also undergo very strict and conscientious function and quality tests before leaving the factory for delivery to our clients. We can assure you that the MOVISTROB® product you received is in strict conformity with our high quality standards and it fully meets all safety and performance requirements.

All relevant data on this instrument are electronically stored and can be recalled at any time.

Upon delivery, the instrument complies with the required safety regulations. To maintain this condition and to ensure safe operation, it is absolutely essential to follow the instructions below.

Advice

We therefore highly recommend to study the following Operating Instructions very thoroughly prior to first use of the stroboscope. Besides technical informations the instructions contain also important hints for use and application as well as special cautions against damage or injury.

Please note that we feel not responsible for any kind of damages or defects caused to the instrument by inappropriate handling or operation nor in case of unauthorized electrical or mechanical actions or alterations to the unit.

2. General Description and Application

This pocket-size, microprocessor-controlled stroboscope is fitted out with a longlife Xenon flash tube.

It is a source of intermittent white light with high light intensity and long lifetime.

The flash rate is continuously adjustable in the range from 150 to 18000 flashes/min. (RPM) corresponding to 2,5 to 300 Hz (flashes/s.).

The average flash duration is about 5 µs.

The stroboscope is housed in an unbreakable plastic case (155 x 95 x 85 mm). Owing to its small weight, compact design and the neat arrangement of all controls, the unit can be easily carried and conveniently single-handed operated.

The "N/A" units are provided with a 2 m long power cable with safety plug for connection to the AC line.

The "B/A" unit *ordered without battery set model 2020.01* will be automatically delivered with a 5 m two-core wire incl. mounted-on BNC plug and alligator clips for connection to a 12 V DC car or similar battery. The red clip is plus (+) and the black one is minus (-).

The battery set type 2020.01 includes a plug charger as well as a 1 m long two-core spiral cable with 3-pin BNC plugs both ends. The extension length of the spiral cable is approx. 2,50 m.

The fine adjustment of the flash frequency for the analog models "N/A" and "B/A" will be effected by an anti-parallax scale potentiometer in Hz (flashes/s.) and RPM (flashes/min.).

The MINISTROB models 3000 have been specially designed for studying fast periodic or quasiperiodic motions (e.g. of rotating or vibrating objects) as well as for contactless and wattless measurement of speed rotation or vibration frequencies.

Moreover, all types of MINISTROB 3000 series are suitable for use as a light source in speed flash photography by which also fast, non-periodic processes (e.g. impact and fall) can be studied.

CAUTION!

Persons with limited physical, sensorial or mental abilities are not allowed to use the unit, unless they are supervised for their safety by a qualified person or are briefed by the responsible person how to use the unit.

Use of this product may induce an epileptic seizure in those prone to this type of attack.

Objects viewed with this product may appear to be stationary when in fact they are moving at high speeds.

Always keep a safe distance from the observation object and do not touch the target.

There are high voltages present inside this product. Refer to the section on lamp replacement before attempting to open this product.

Do not allow liquids or metallic objects to enter the ventilation holes on the stroboscope as this may cause permanent damage.

The instrument may be operated by trained personnel only. Maintenance and repairs may also be carried out by qualified personnel or by the manufacturers only.

3. Controls and Indicators

The instrument carries the following controls and functional components (see figure):

3.1 Mains Pushbutton (1)

switches on the instrument by depressing the pushbutton

3.2 Flash Frequency Range Selector Pushbutton (2)

sets flash frequency of the two power ranges

Low Range: 150 → 4000 RPM (fl./min.) = 2,5 → 67 Hz (fl./s.) (button in depressed position)

High Range: 3700 → 18000 RPM (fl./min.) = 61 → 300 Hz (fl./s.) (button not pushed)

3.3 Control Knob with Dial Scale (3)

for continuous adjustment of flash frequency exactly to the required value within the pre-selected range (3.2).

There are two dial graduations on the transparent dial mask of the analog units corresponding with the two frequency ranges. The outside division of the scale shows the flashes per minute = RPM in black figures and the inside circle states the flash frequency in flashes per second = Hz (red figures) with an accuracy of less than 2 % of the set value.

There is an index line on the housing for proper reading.

3.4 Flash Bulb with Reflector (4)

The Xenon longlife flash bulb is inserted inside the housing in a 3-pin socket behind the mirror reflector, protected by the transparent fiberglass cover.

Changing the transparent cover for a red filter type **2000.11**, the fiberglass cover can easily be removed by unscrewing the 4 screws on the button of the housing (see drawing and instruction for change of the flash bulb). The red filter supplies a selective contrast to daylight and prevents the human eye from early stress and symptoms of fatigue in case of longtime observations.

However the red filter will definitely reduce the light intensity.

4. Installation

Check whether the instrument is adapted to the nominal AC or DC voltage as given on the type plate.

After switching on by pressing pushbutton " 1 " it is instantly ready for operation.

When using higher (or lower) flash rates, however, in order to initiate the first flash, the range button " 2 " must be depressed. If hereby the non-desired range is switched on, the button must be operated once again.

Illuminate the object with the MINISTROB. Set the flash rate by means of push button " 2 " and control knob " 3 ", so that an apparently stationary or slowly moving object will be visible.

5. Stroboscopic Principle

With stroboscopy, high-speed periodic motion which cannot be followed by unassisted eyes can be made accessible for observation and its frequency measured. For this purpose the oscillating or rotating object is illuminated in a periodic series of light impulses (flashes) which are as brief as possible. The object then appears (at the appropriate flash frequency) to be motionless (stopped image) or slowed (slow-motion). The object's behavior and motion can thus be observed in all their details. At low frequencies in the flash rate (below about 30 Hz) a certain flickering of the image is unavoidable. To make the visual perception appear real requires a solid-colored disc with a single eccentric mark.

5.1 Stopped image of the object

If the rotating object (or the mark) is to appear to the observer as a stopped image under stroboscopic light, the period **T** of the flash frequency must be a whole-number multiple **n** of the rotation period **r**:

$$\mathbf{T = Tn = nr}$$

For the corresponding frequencies $\mathbf{f = 1/T}$ and revolutions $\mathbf{v = 1/r}$ the relationship is:

$$\mathbf{f = fn = 1 v \div n}$$

The highest flash frequency (**n = 1**) which produces a stopped image of the object, i.e. the mark equals the revolutions: $\mathbf{f1 = v}$ (stopped images in which the mark appears more than once still result from flash frequency $\mathbf{f > f1}$).

The observed phase of the rotation in stopped image, i.e. the rotational angle at the moment of the flash, is purely accidental. Through brief changes in of the flash frequency however the desired phase position can be adjusted approximately. In the same way, RPM fluctuations can cause a change in phase position. Exact phase stability, i.e. sharply stopped image, can be achieved when the flash frequency is controlled externally by the moving object (does not apply for MINISTROB series 2000).

5.2 Measurement of RPM and frequencies

To measure the RPM v either the highest flash frequency $f_1 = v$ which results in a stopped image of the object can be determined, or two neighbouring flash frequencies f_n and f_{n+1} can be determined and from these the rotational frequency computed. For the periods for f and f_{n+1} in the flash frequency the equation is:

$$r = T_{n+1} - T_n$$

From this we derive the frequencies:

$$v = f_n \cdot f_{n+1} + f_n - f_{n+1}$$

5.3 Slow-motion cycle

If the period T of the flash frequency deviates slightly from a whole-number multiple $T_n = nr$ of the rotation time r of the object, i.e.

$$T = (n + e) r \text{ with } |e| < 1$$

then the object no longer appears stopped, but has rotated through the angle $2e$ between two succeeding flashes. If $|e|$ is sufficiently small the eye perceives a constant slow-motion cycle. Angular speed w' , at which the object appears to rotate, is given by:

$$w' = 2v' = \frac{2\pi e}{T} = \frac{2\pi e}{(n+e)r} = \frac{2\pi e}{nr}$$

If we compare this with the true angular speed of the object, we obtain:

$$w' = (e + n) \cdot w$$

For $e > 0$ (i.e. $T > T_n$ and/or $f > f_n$) w and w' have the same sign, so that true and apparent rotation are in the same direction.

The opposite holds for $e < 0$. With increasing $|e|$ the angular speed w' of the apparent rotation rises. Finally the angle $2\pi e$ becomes so large that the mark on the rotating disc appears at two different places during two succeeding flashes. Other phenomena (described below) also occur.

5.4 Stopped images of phantom objects

Stopped images of rotating objects results from flash frequency periods $T_n = nr$, and also at other flash frequencies. However, the latter represent phantom objects, not the real object. Using the example of the rotating disc with an eccentric mark, it is obvious that stopped images also occur when:

$$T = (n + k) r \text{ and / or } f = (k + n) v,$$

whereby n and k are whole relatively-prime numbers. The stopped image shows k marks, which are arranged in the corner of a regular k -angle. Only a very few of the theoretically infinite number of flash frequencies result in observable images, since at each corner of the k -angle there is only one mark for k sequential flashes, but $(k - 1)$ times no marks. As k increases then the images have less and less contrast. The images of the real object ($k = 1$) always appear sharpest.

In addition, the images become more and more faint at a given k with increasing n . The interval in which the mark is illuminated at one corner of the k -angle amounts to n rotation periods. In conclusion, the k mark images must not overlap. Altogether we may expect observable images only with low values of n and k . In objects with a complicated texture the phantom objects mostly disappear in an untextured background.

5.5 Objects with a finite rotational symmetry

In many cases the axis of the rotating object is an **m**-number symmetrical axis, i.e. the object overlaps itself through a rotation about the angle $2/m$. In the example of the disc this is achieved through **m** equal marks which are arranged in the corners of a regular **m**-angle. In this case substitute r/n for the period **r** in the relationships derived above.

Stopped images of the real object therefore result from

$$T = (n + k) r \quad \text{and /or} \quad f = (k + n) v,$$

In addition, stopped images of phantom objects also occur for

$$T = (n + k) \cdot (r + m) \quad \text{and /or} \quad f = (k + n) (m \cdot v)$$

(**k, m, n** are whole numbers). If **k** and **n** are selected relatively-prime, **k.m** marks appear in the corners of a regular **k.m**-angle.

6. Replacing Flash Bulb and Fuses

Caution

Before attempting to open the housing make sure the stroboscope is turned off and disconnected from the mains respectively battery.

If there is repeated flash failure or complete breakdown, the flash bulb must be replaced. For this purpose the 4 setscrews (1) underneath the base of the housing must be removed. Now lift off the upper part of the housing (2) gently and remove the transparent cover (3) by sliding it cautiously upward.

In any case do not remove the Control Knob with Dial Scale!

Allow the flash bulb to cool but wait at least 2 minutes before attempting to exchange it. Proceed very cautiously when pulling the 3-pin bulb out of its socket. Insert the new bulb (incorrect insertion not possible) and, if necessary, remove fingerprints by means of a soft cloth. In case the flash bulb fits in very tight loosen it carefully with a screwdriver applied as a lever between bulb base and socket and pull the bulb out. Only after the housing has been properly closed should the instrument be put into operation again.

It may take up to one hour before a new tube produces an uninterrupted flash sequence.

After the upper part of the plastic housing has been removed, the fuse is accessible and can be replaced.

The following fuses are being used:

MINISTROB 230V AC	MINISTROB 115V AC	MINISTROB 12V DC
Code No. 3110	Code No. 3111	Code No. 3118
0,400A T	0,63A T	3,15A T

Note

Do not use the flash bulb needlessly, as its life expectation is limited to an average of approx. 350 hrs. You will achieve a much longer lifetime, if you switch the instrument off in case of longer intervals in between the measuring or motion control actions.

The capacity of the battery depends on the frequency of the stroboscope and may change between 0,6 A and 2,5 A depending on the setting of the flash range.

Flash bulbs and batteries are expelled from warranty.

CAUTION

When connecting the MINISTROB type 3000 B/A with the battery, please make sure:

Pin 1 **plus**
Pin 2 **n.c.**
Pin 3 **minus (ground)**

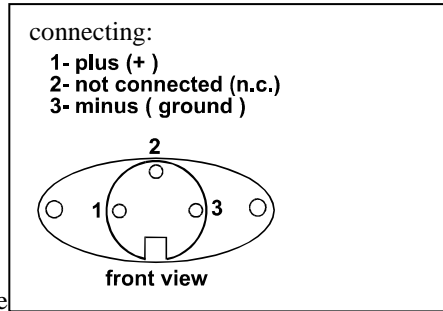

7. Maintenance and Repair

If the instrument is suspected of being unsafe is usually the case when the unit shows physical damage, no sign of functioning or stress beyond the tolerable limits. Repair, replacing parts, calibration ect. should be carried out by trained personnel only or preferably return it to the manufacturer for inspection and control.

<u>TECHNICAL SPECIFICATIONS</u>	<u>MODEL 3000 N/A</u>	<u>MODEL 3000 B/A</u>
Supply voltage:	220-250 V AC, 40-60 cy/sec 115 V AC , 40-60 cy/sec	Specifications and technical data are as per model 3000 N/A
Light source:	Socket-mounted XENON-longlife	
Light intensity:	450 lux max.	
Flash duration:	approx. 2-7 μ s	SUPPLY VOLTAGE: 12 V DC, input 0,6..
Frequency range:	2.5...300 cy/sec	2,5 A
Range division:	I. 150 - 4000 RPM II. 3700 - 18000 RPM	Incl. 5 m cable for connection of external battery.
Accuracy:	less than \pm 2 % of dial	24V DC operated units on special request
Casing:	shatterproof plastic	
Weight:	approx. 600 grs	
Dimensions:	155 x 95 x 85 mms	

In correspondence concerning the instrument, please quote the type number and serial number as given on the type plate underneath the bottom of the housing.

Right of technical modification reserved

MINISTROB 3000 N/A and 3000 B/A

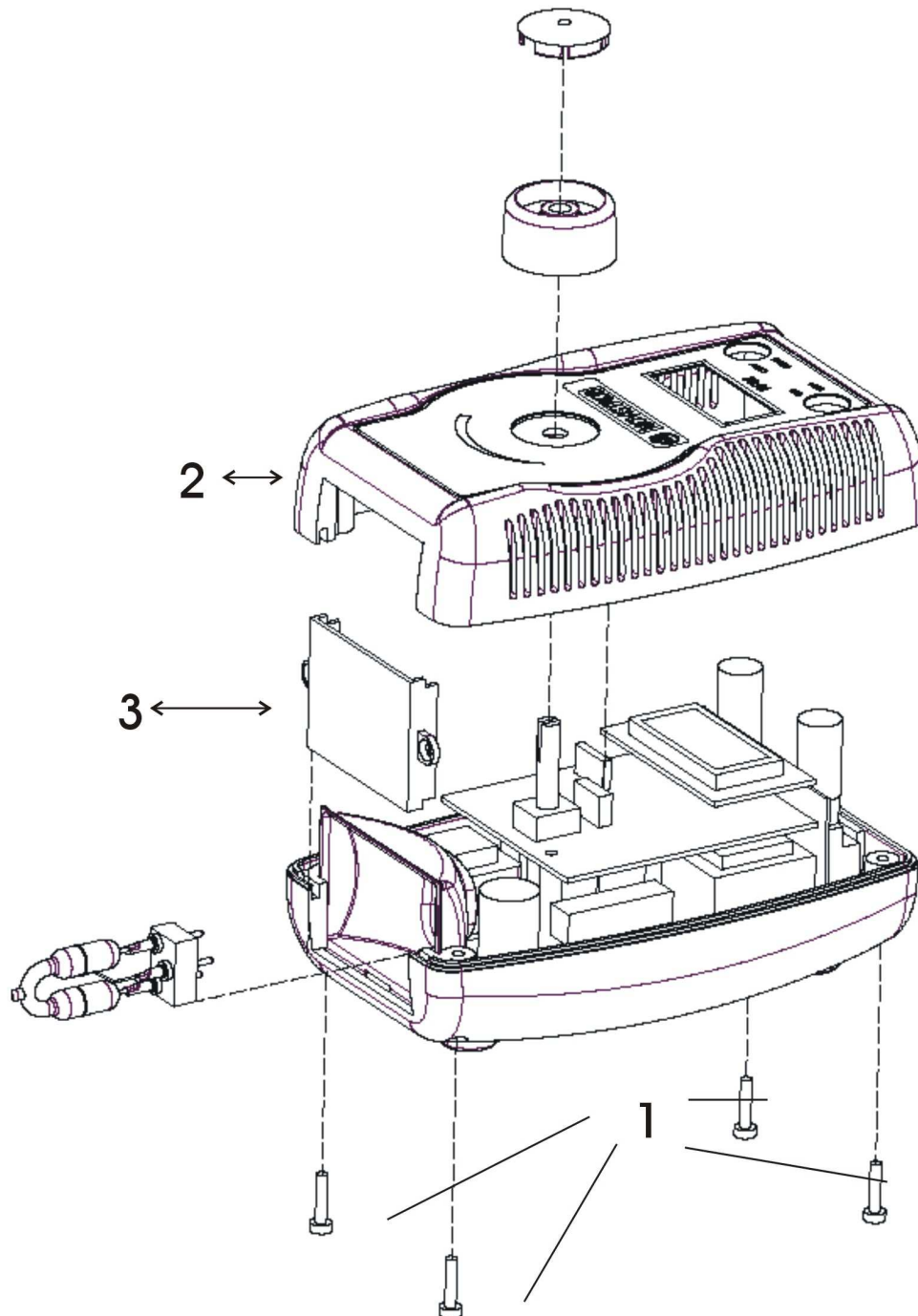

Anleitung zum Wechseln der Blitzröhre

Zuerst die mit 1 gekennzeichneten Schrauben lösen. Danach Oberteil (2) abnehmen. Jetzt die Frontscheibe (3) entfernen und die Röhre austauschen.

Instruction for change of the flash bulb

At first disengage the 4 screws (1). Now remove the upper part (2) of the housing. After taking off the transparent cover (3) the flash bulb can now easily be exchanged.

Information in accordance with battery regulation

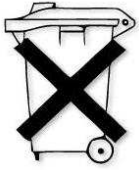

With regard to the sale of batteries and accumulators, we are obligated as retailer to inform you as consumer about the following: you are legally obligated to return batteries and accumulators. You can return them after using in our shop, in a communal collection point or in local shops. Batteries containing hazardous substances are marked with a symbol consisting of a crossed out dustbin and the chemical symbol (Cd, Hg or Pb) for the heavy metal that has been the decisive factor for declaring the hazardousness.